

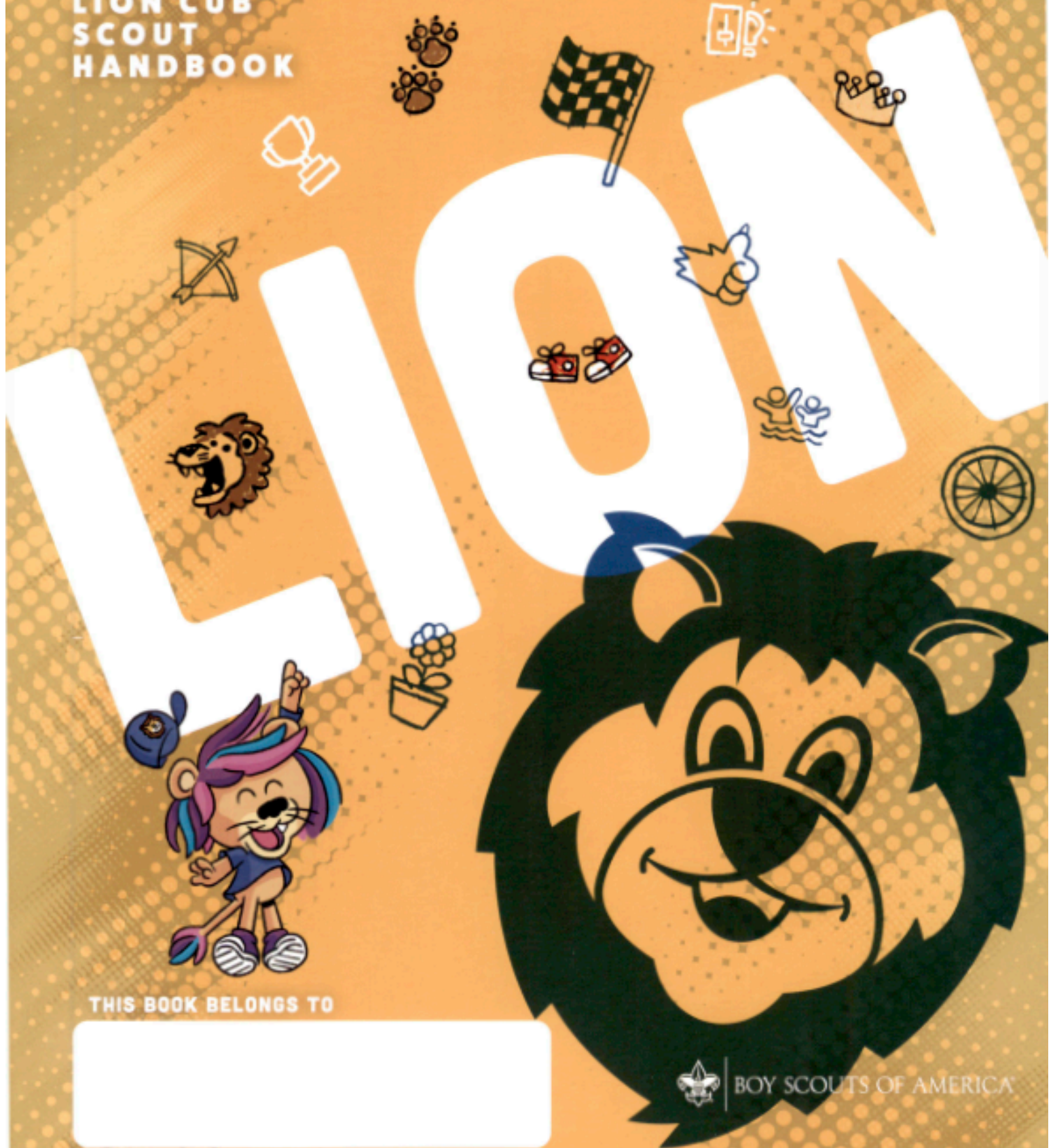

LION CUB
SCOUT
HANDBOOK

KINDERGARTEN



THIS BOOK BELONGS TO



BOY SCOUTS OF AMERICA

My Lion Trail



Bobcat
(Character & Leadership)

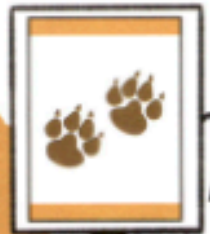

Mountain Lion
(Outdoors)

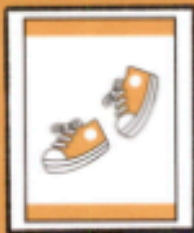

Fun on the Run
(Personal Fitness)

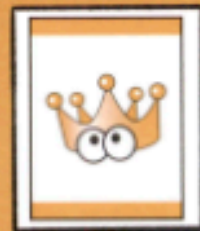

King of the Jungle
(Citizenship)



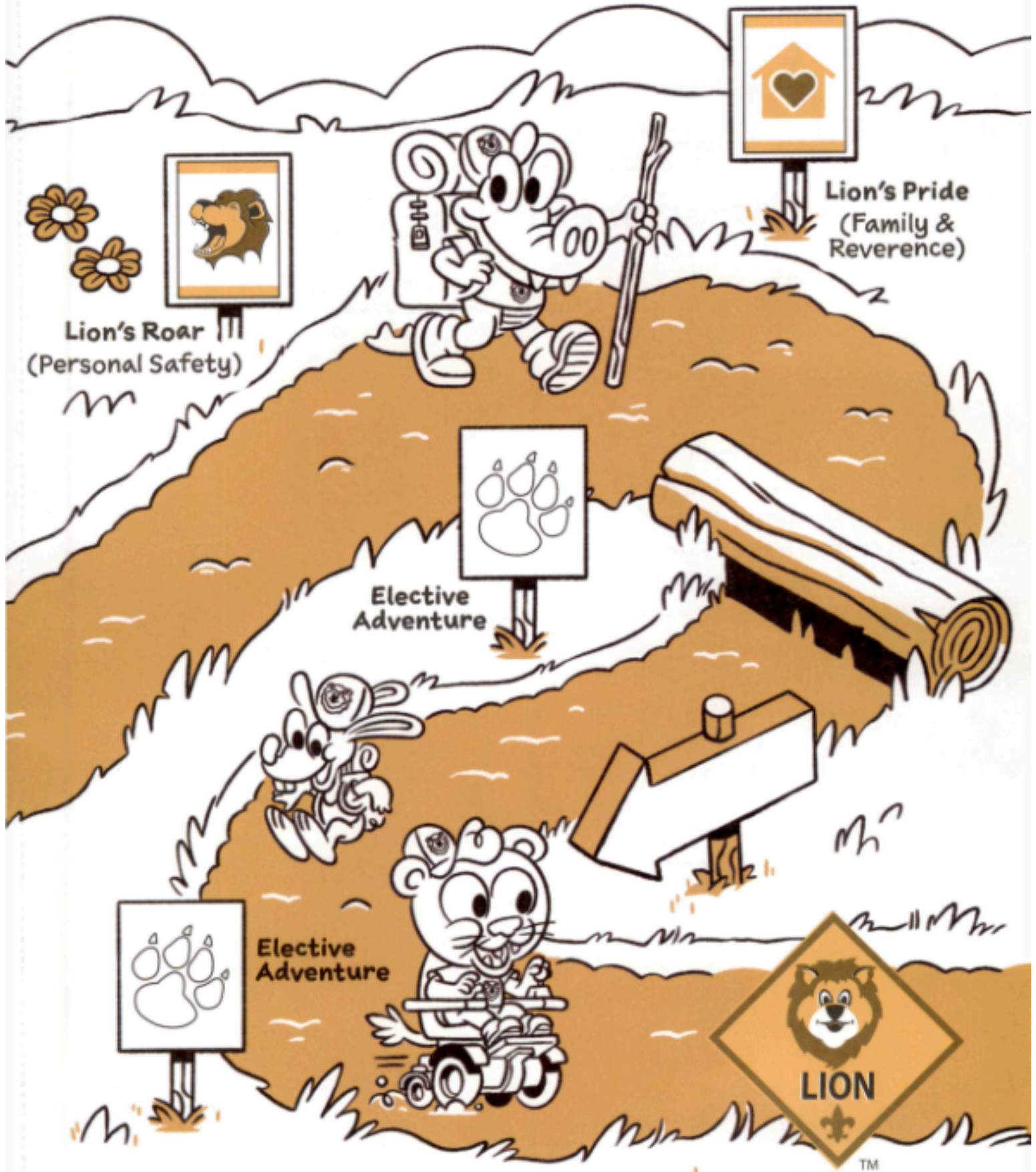

Lion's Roar
(Personal Safety)

Lion's Pride
(Family & Reverence)

Elective Adventure

Elective Adventure

Elective Adventure

LION

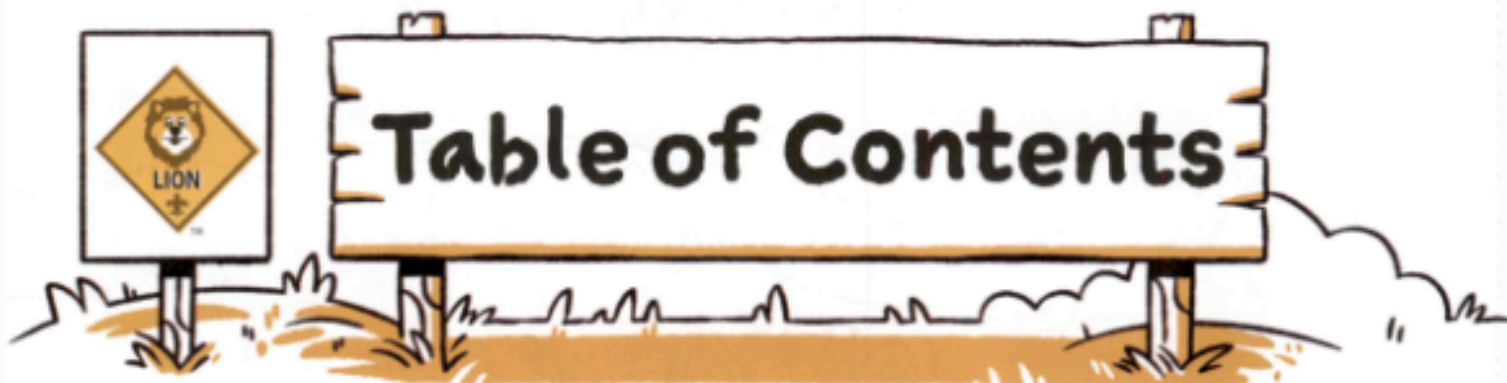

ATTENTION ADULT PARTNERS

Begin by reading the Adult Partner Guide that came with this Lion Handbook. The activities in this Lion Handbook are designed to help introduce topics of Adventures and supplement requirements. Completing the activities in this handbook alone does not meet the requirements for the Cub Scout Adventure or for the Lion badge of rank.

Contents

My Lion Trail	1
Bobcat (Character & Leadership)	3
Mountain Lion (Outdoors)	9
Fun on the Run (Personal Fitness).	13
King of the Jungle (Citizenship).	16
Lion's Roar (Personal Safety)	19
Lion's Pride (Family & Reverence)	22
Build It Up, Knock It Down	25
Champions for Nature	28
Count On Me.	30
Everyday Tech.	33
Gizmos and Gadgets	35
Go Fish	38
I'll Do It Myself	42
Let's Camp	47
On a Roll.	51
On Your Mark	54
Race Time.	55
Pick My Path.	57
Ready, Set, Grow	60
Time to Swim.	63
Adventure Tracking	64

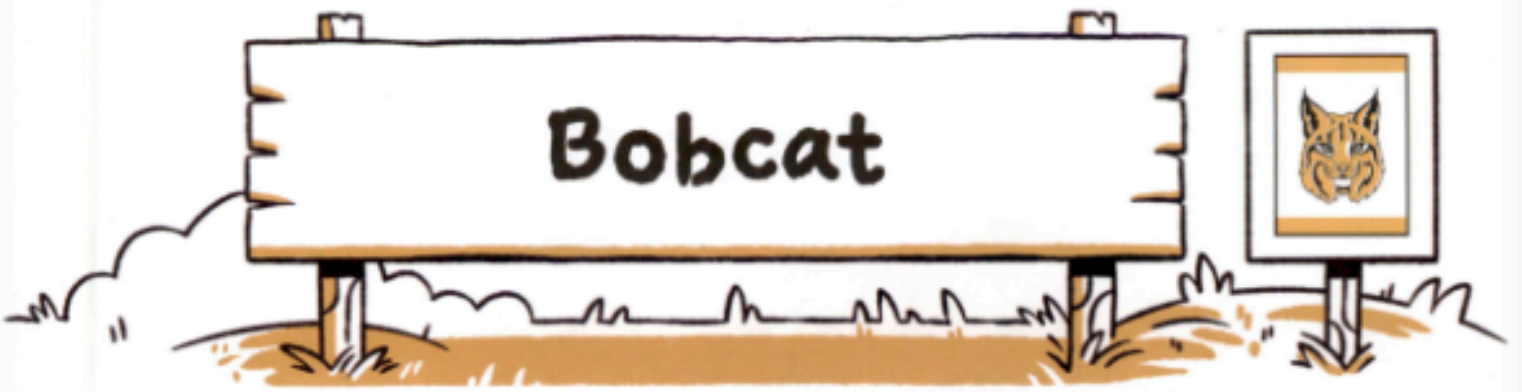

Have the members of your den write
their names or initials here.



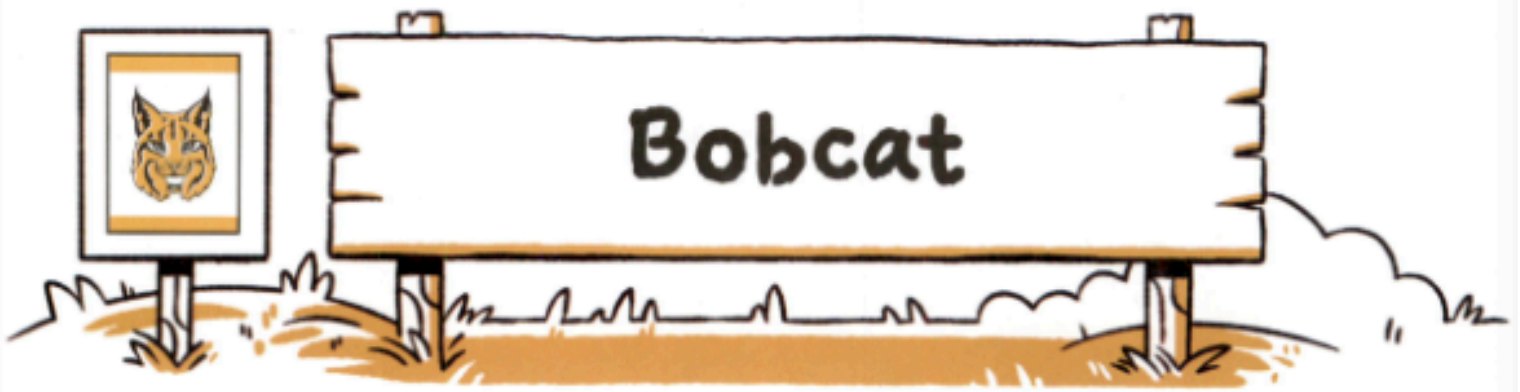

Here are the 12 points of the Scout Law.
Circle the one that shows "friendly."



Trustworthy



Loyal



Helpful



Friendly



Courteous



Kind



Obedient



Cheerful



Thrifty



Brave



Clean



Reverent

Bobcat



The Cub Scout motto is "Do Your Best!"

Color or circle the pictures below that show the
Cub Scout motto of "Do Your Best."

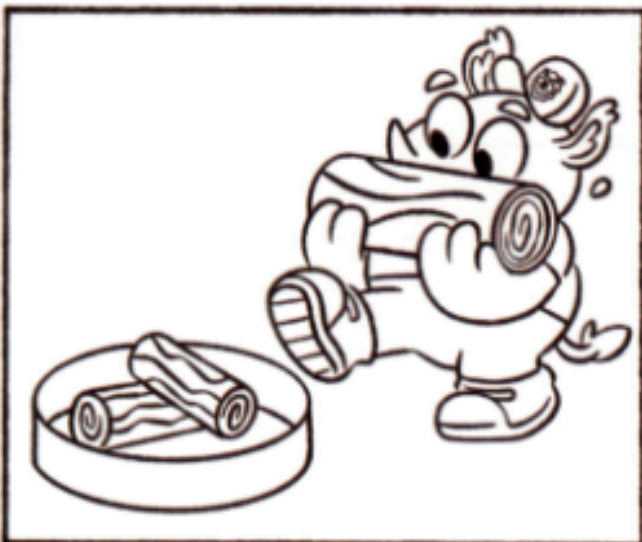
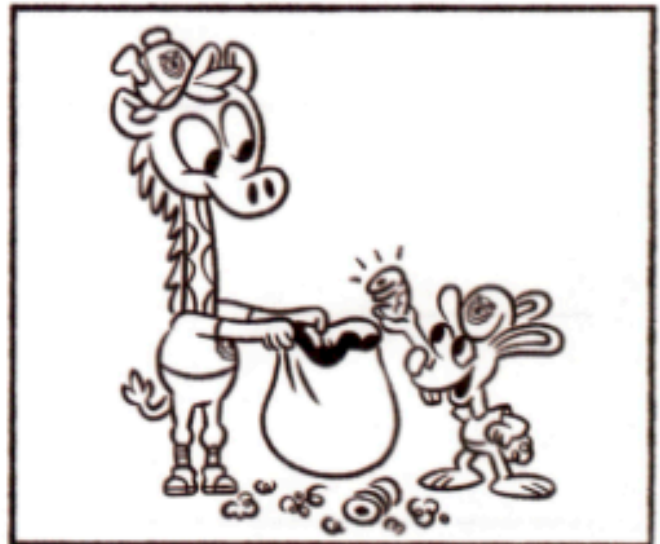
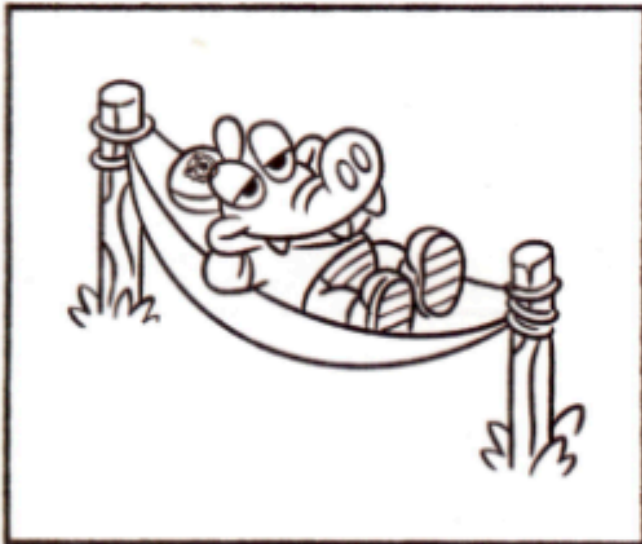

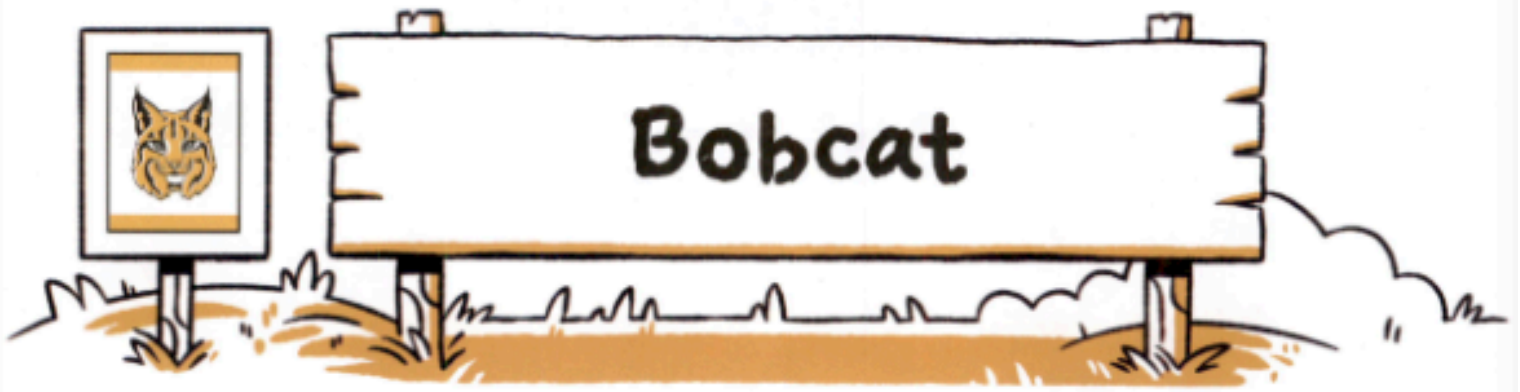

With help from your adult partner, write the names of five trusted adults.



CONGRATULATIONS!

You have completed the Bobcat Adventure!

Color this certificate then
cut it out and hang it on your wall.



This page left blank intentionally so
certificate on page 7 can be cut out.

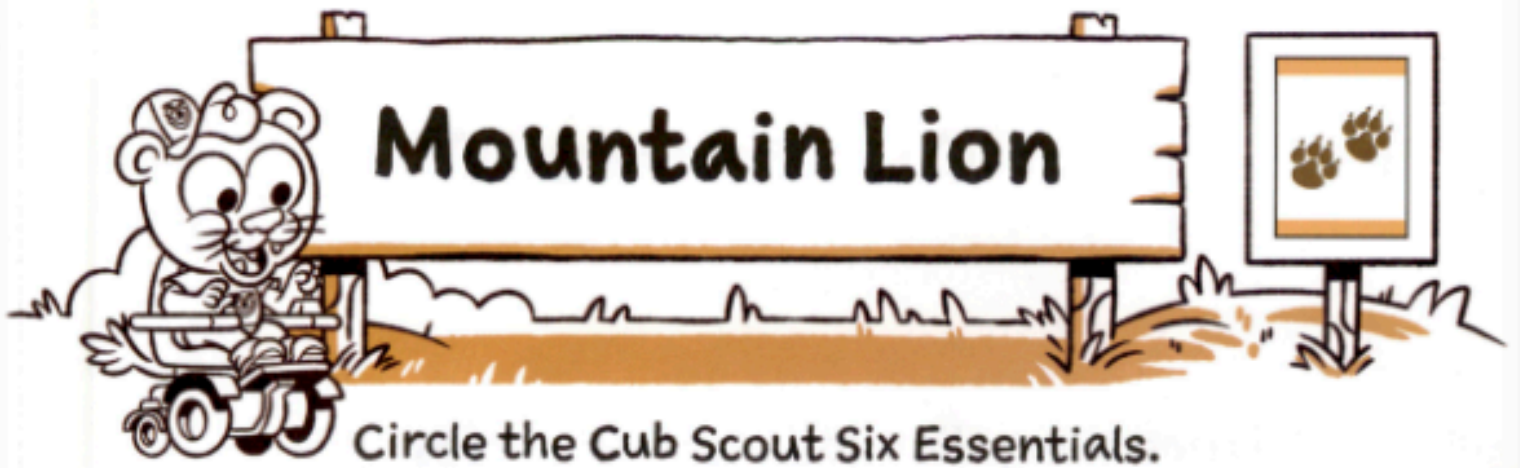

Circle the Cub Scout Six Essentials.

Water bottle, first-aid kit, whistle, flashlight, sun protection, trail food.





Draw one thing that you saw on your walk that was **NATURAL** and one thing that was **MAN-MADE**.

A large, empty rectangular box with a black border, intended for the student to draw their observations. It occupies the upper half of the page below the instructions.A second large, empty rectangular box with a black border, identical to the one above, intended for the student to draw their observations. It occupies the lower half of the page.

Mountain Lion



Kip lost his buddies. Help him find them as they Stay, Answer when he calls, and Whistle.



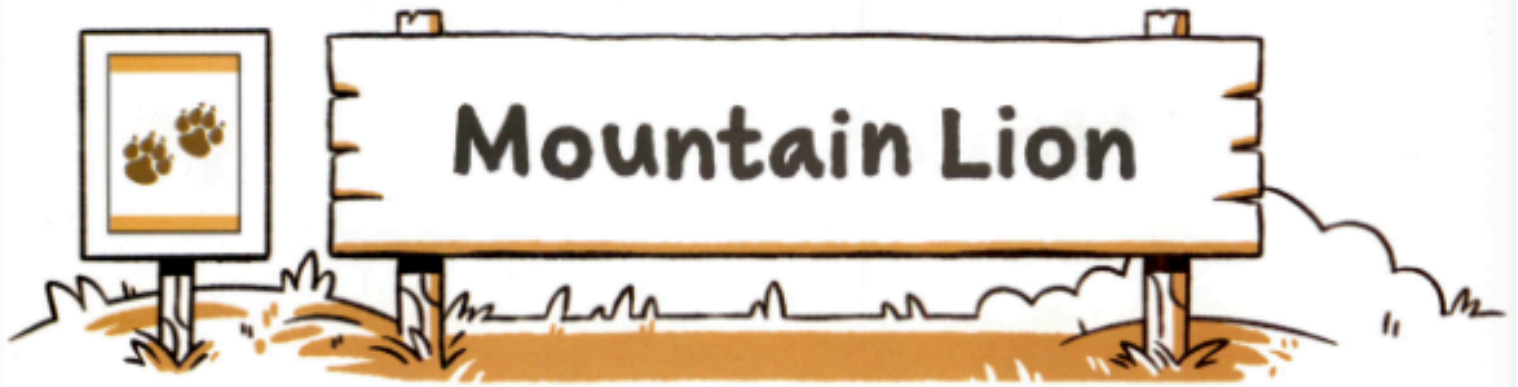

Circle the animals below that are wild animals.

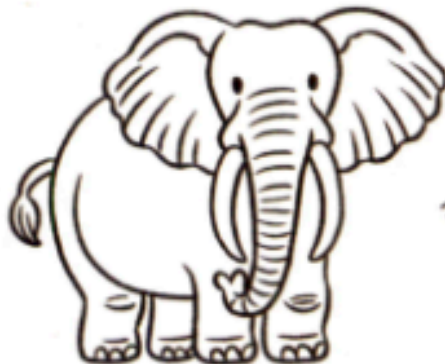
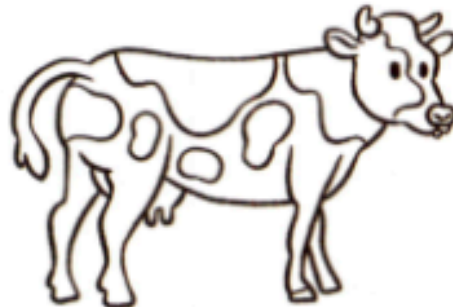

Fun on the Run



Place an X on the food that is in the wrong food group.

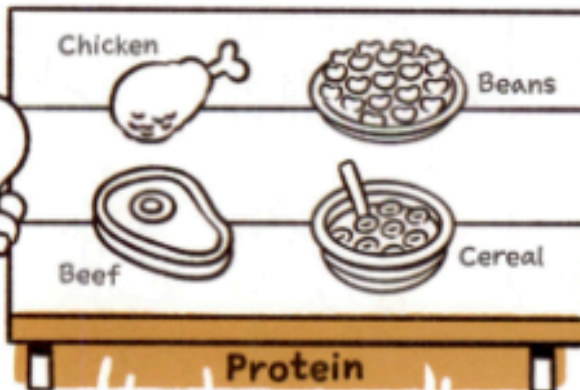
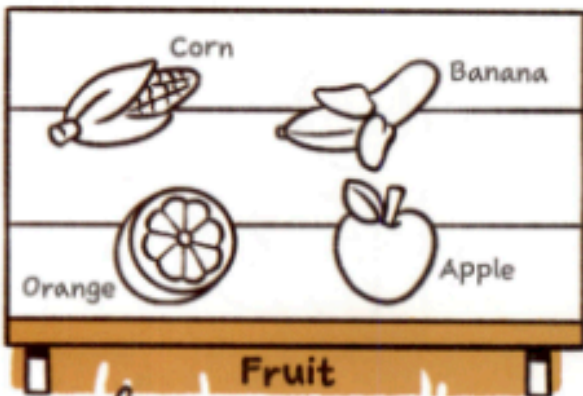
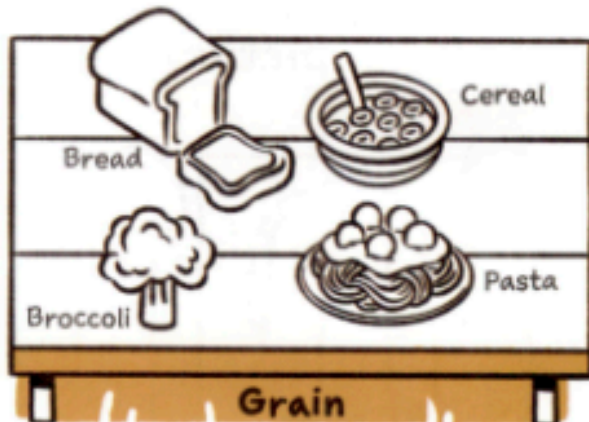
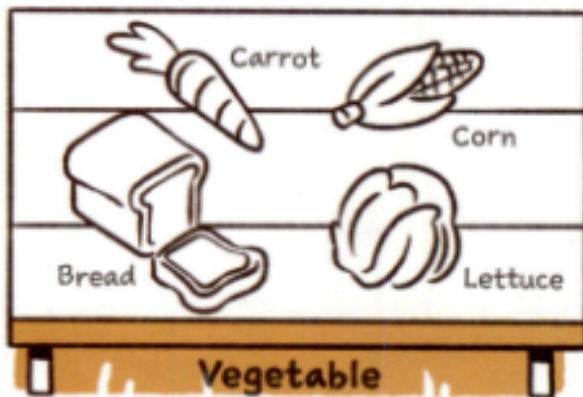

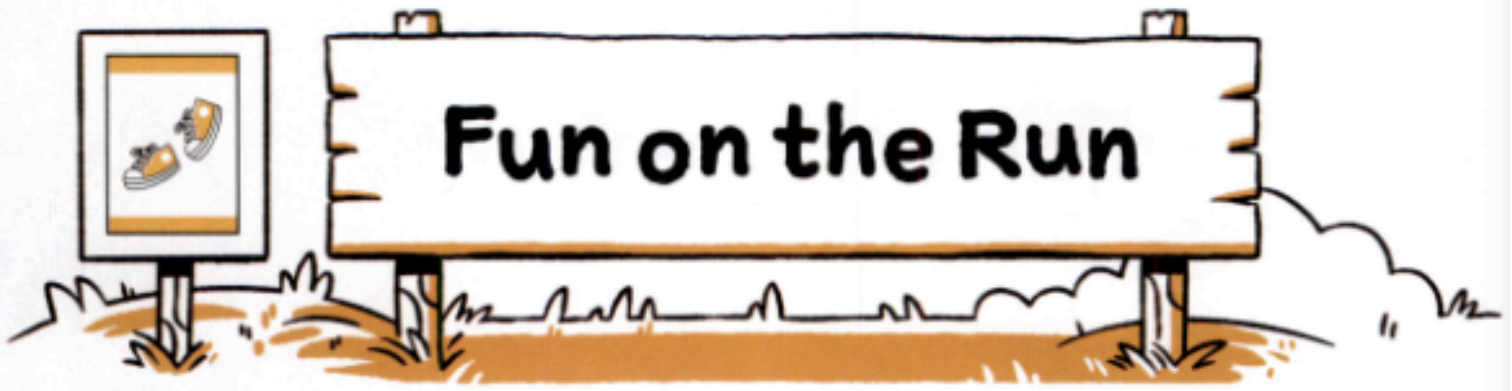

Washing Hands

Write the number next to the step to put the pictures in the correct order.



Dry hands.

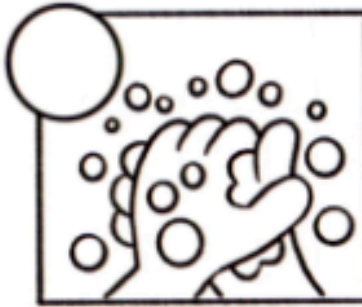

Rub hands together.

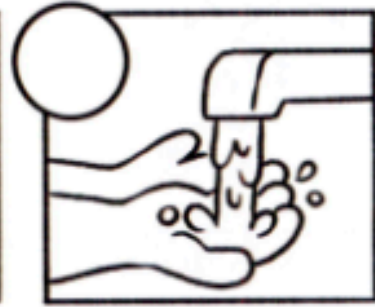

Get hands wet.

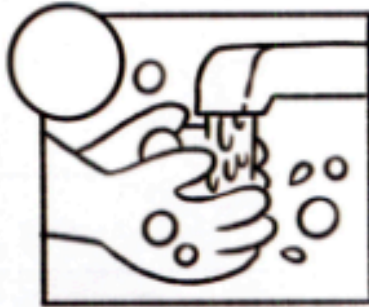

Rinse off soap.



Use soap.

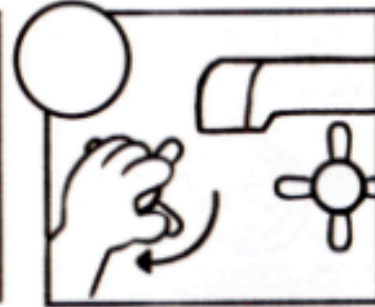

Turn off water.

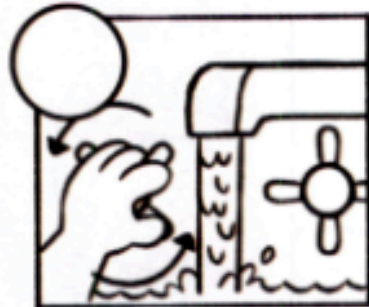

Turn on water.

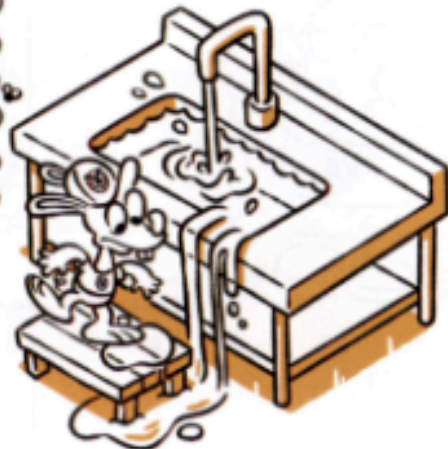

Fun on the Run



Just like animals, you need rest to be healthy.

Draw a line from the animal to the sun if it sleeps in the daytime. Draw a line from the animal to the moon if it sleeps at night.



Owl



Dog



Opossum



Bird



Cat

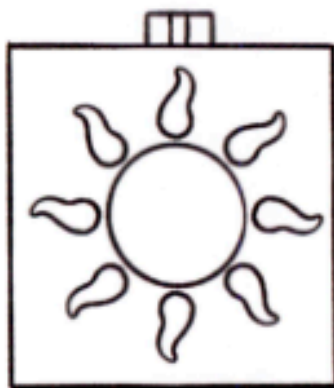

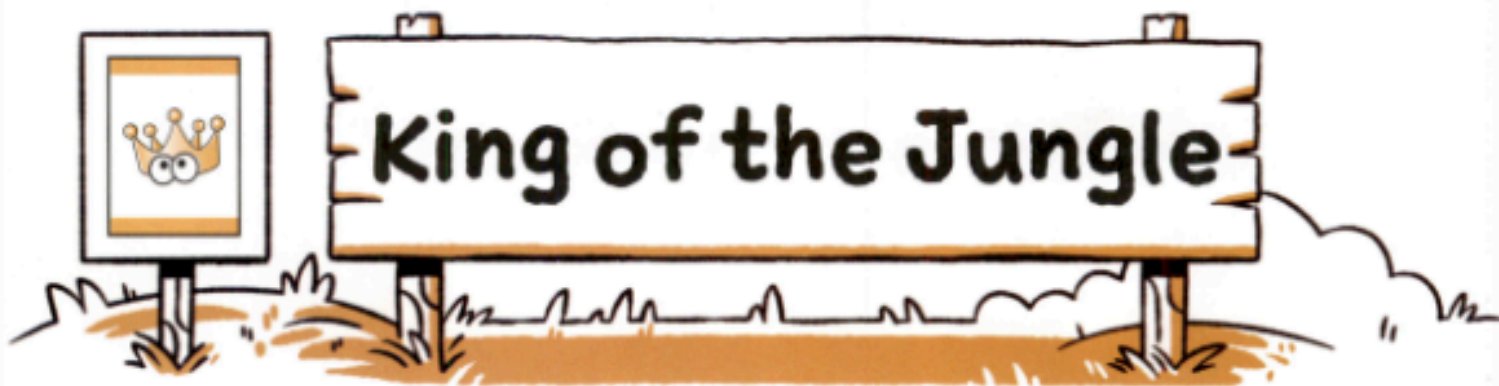

Draw a picture of your family in the frame below.

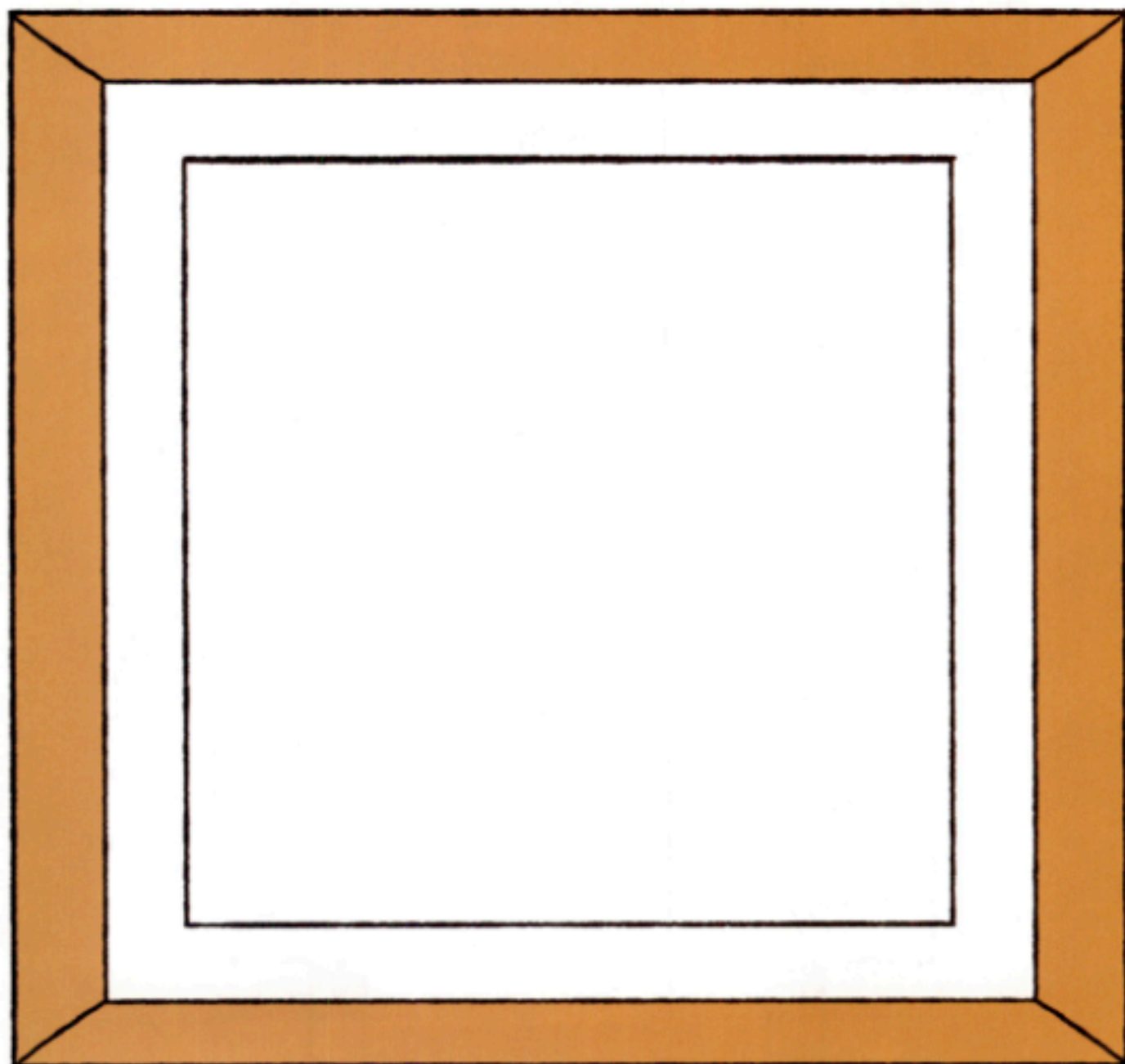

King of the Jungle



Draw a circle around the jobs you do to help your family.

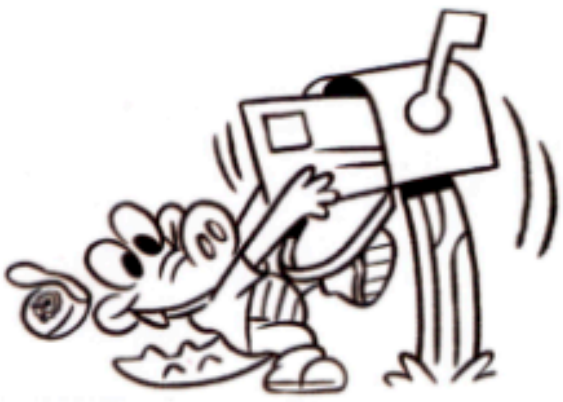
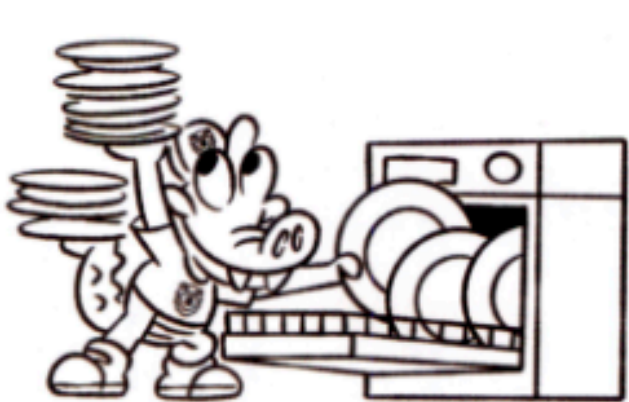
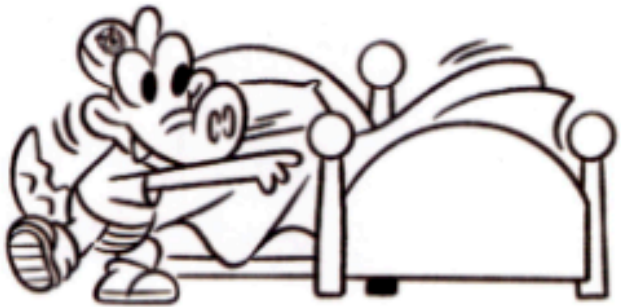
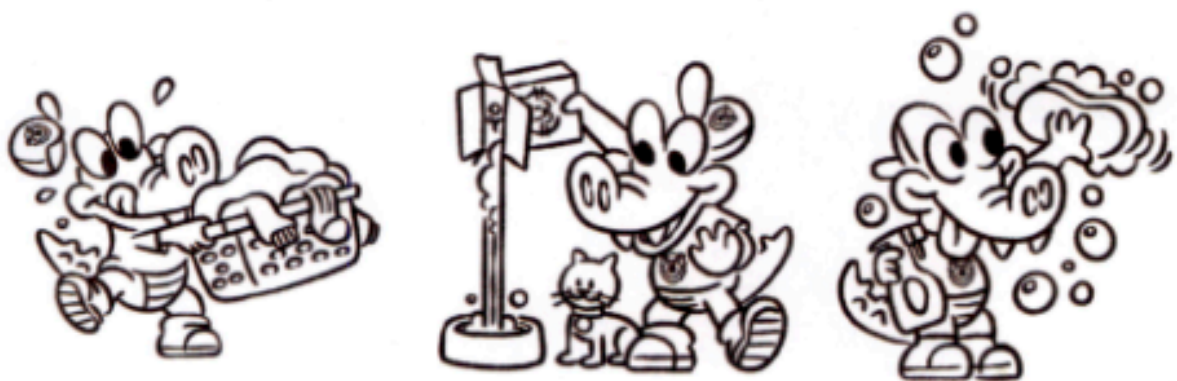

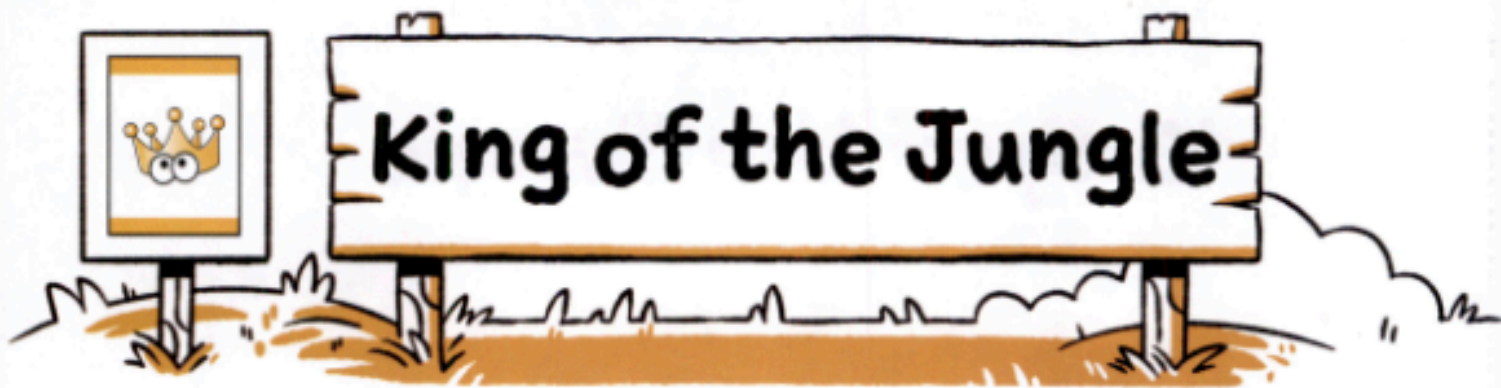

Draw a picture of the service project you did.

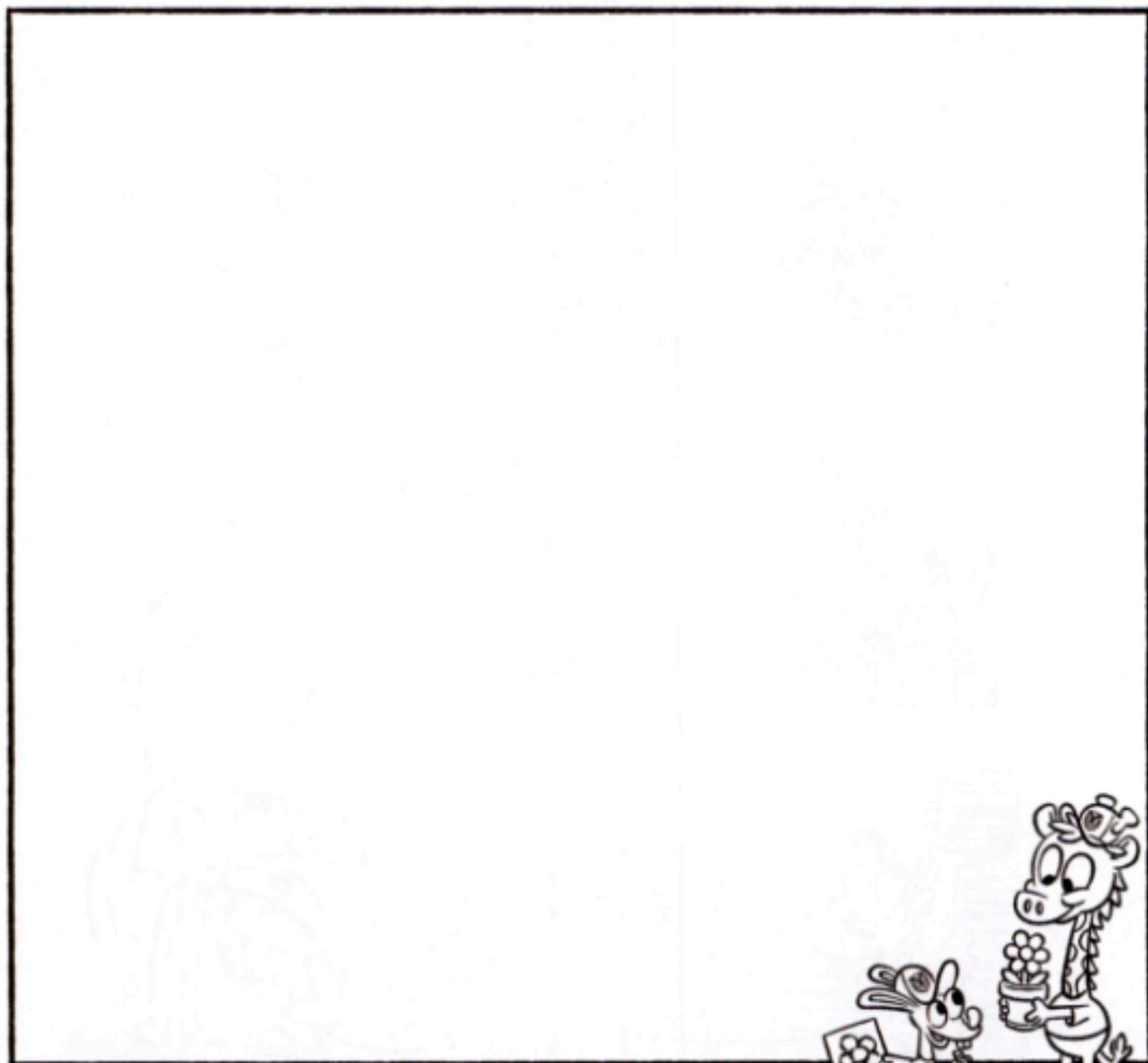

Lion's Roar



With your adult partner, demonstrate **Shout, Run, Tell** as described in the **Protect Yourself Rules** video. Then color the pictures below.

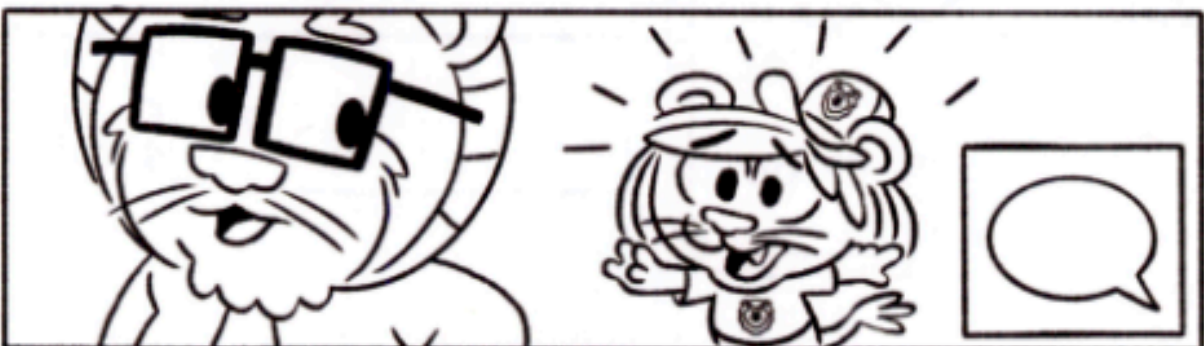
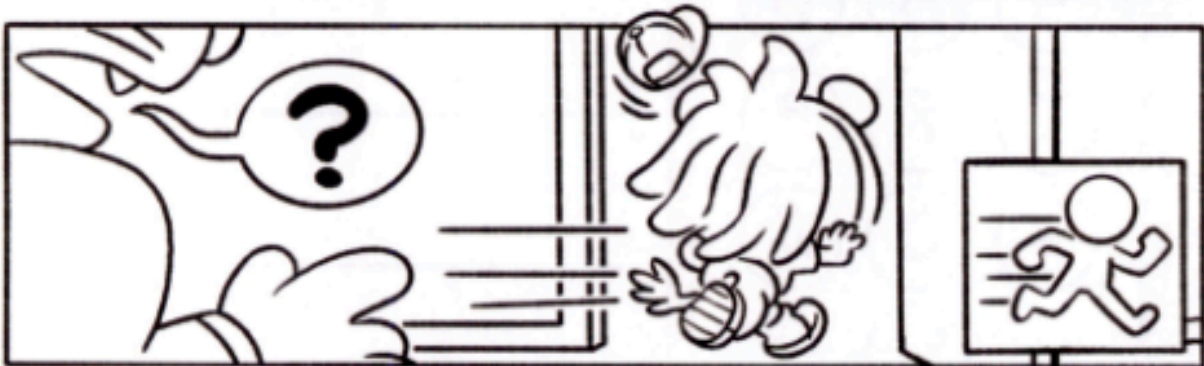



Show how you would call for help.
Add important names and phone numbers for your
trusted adults on the lines below.





Lion's Roar



Complete the dot-to-dot pictures below.
Use GREEN for walk and RED for don't walk.



Walk

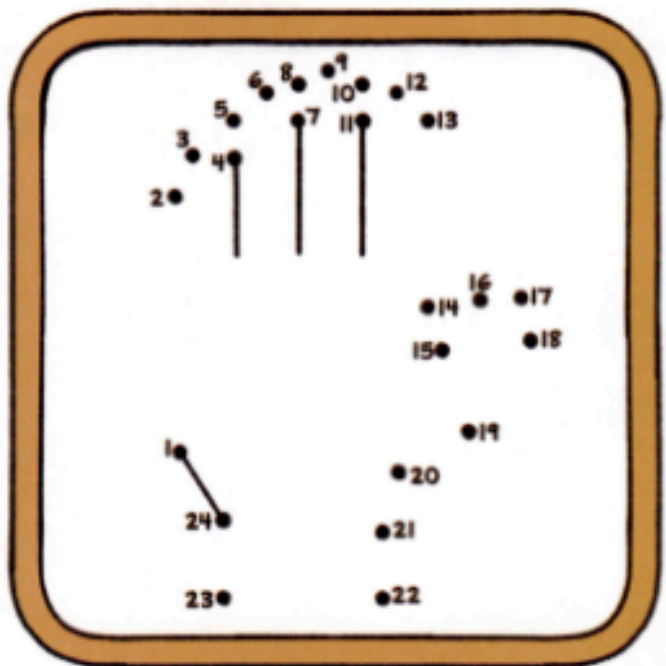

Don't Walk



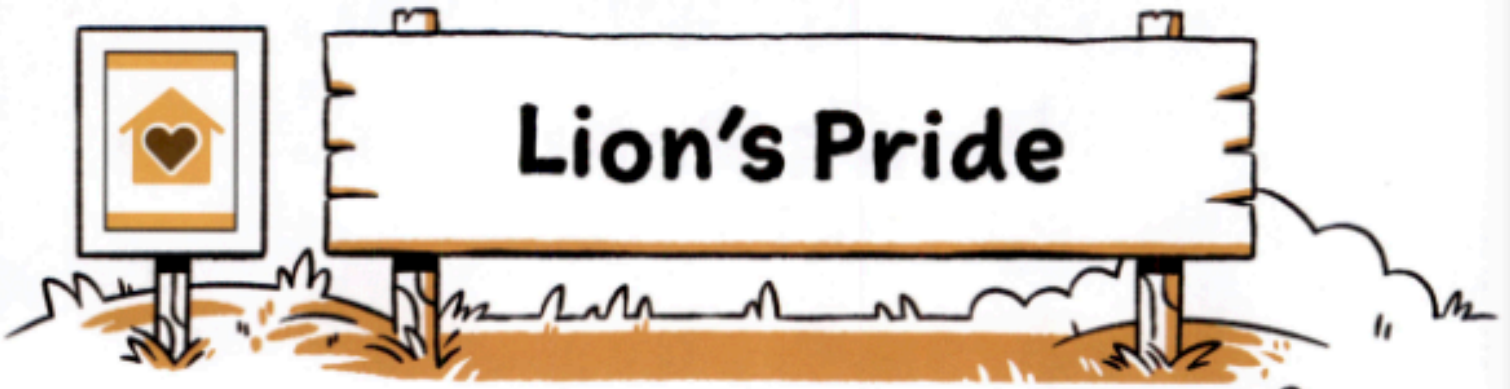

Draw a picture of your favorite family faith tradition.

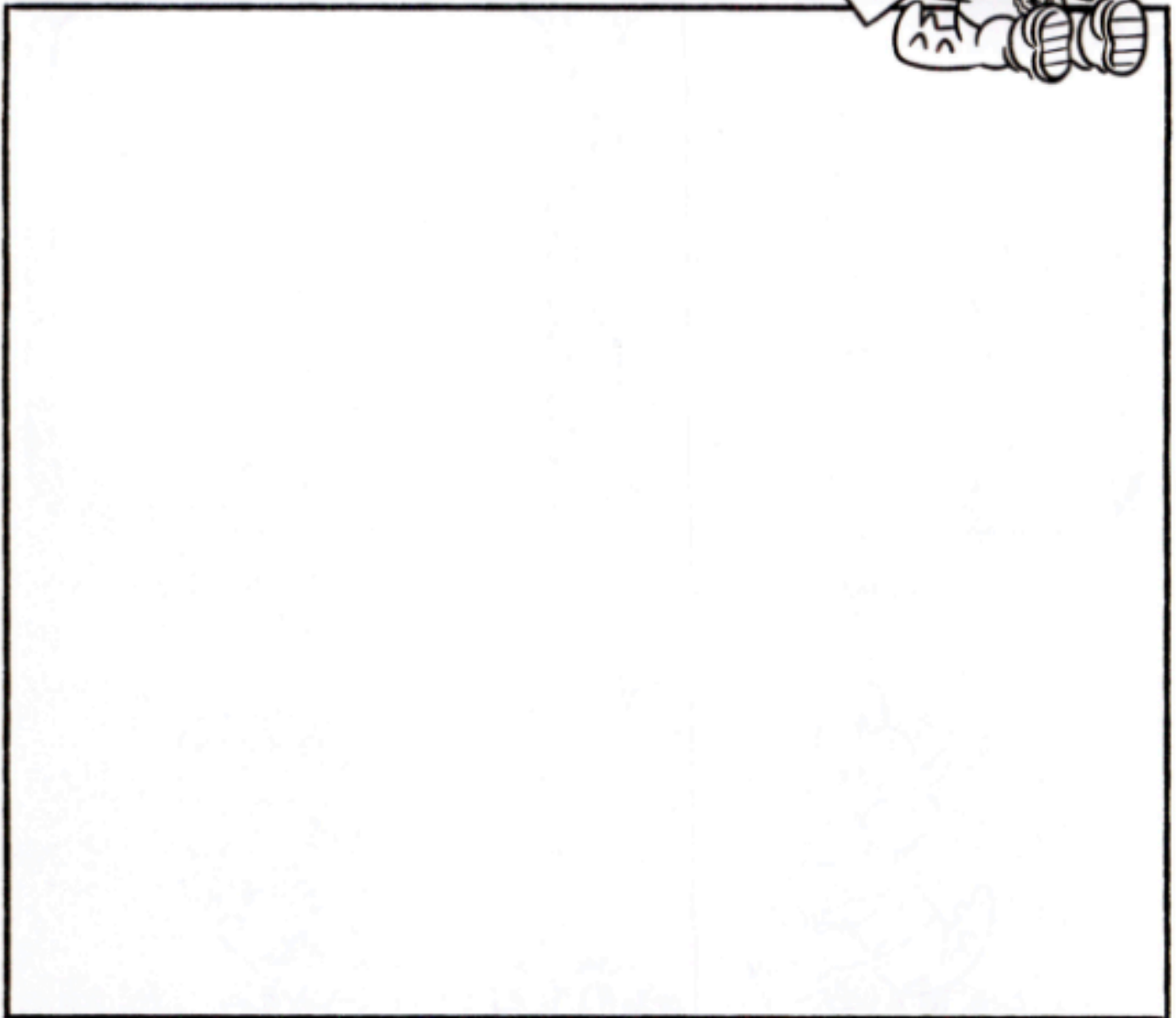
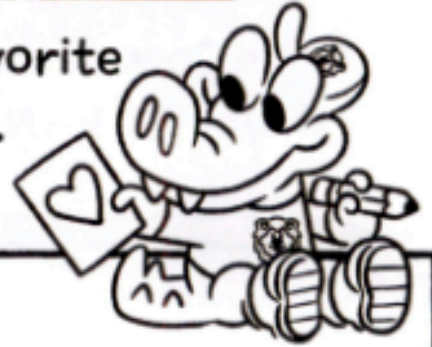

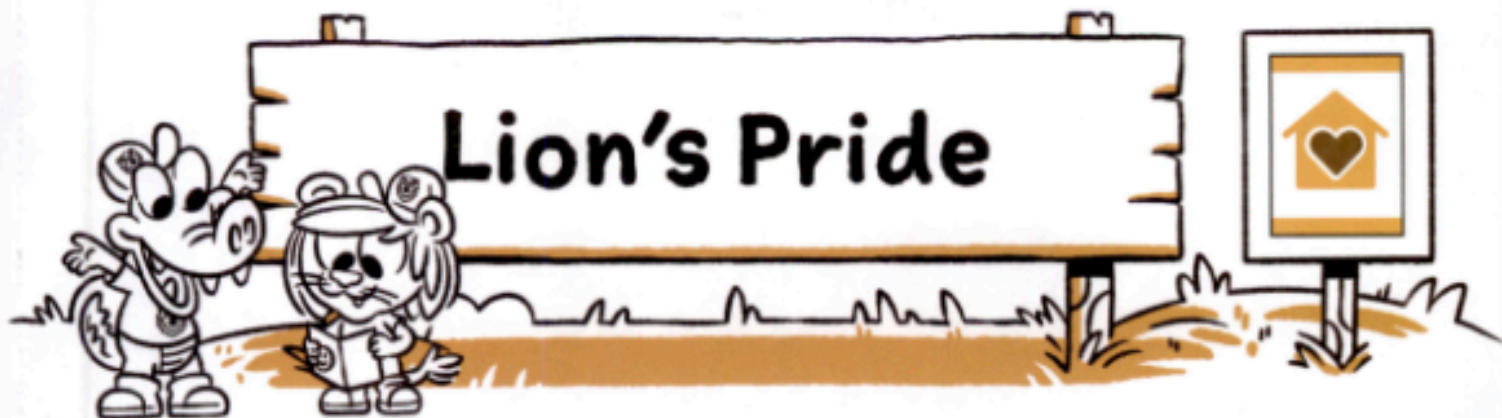

Create a cheerful card to give someone. Cut along the solid lines and fold along the dotted line.

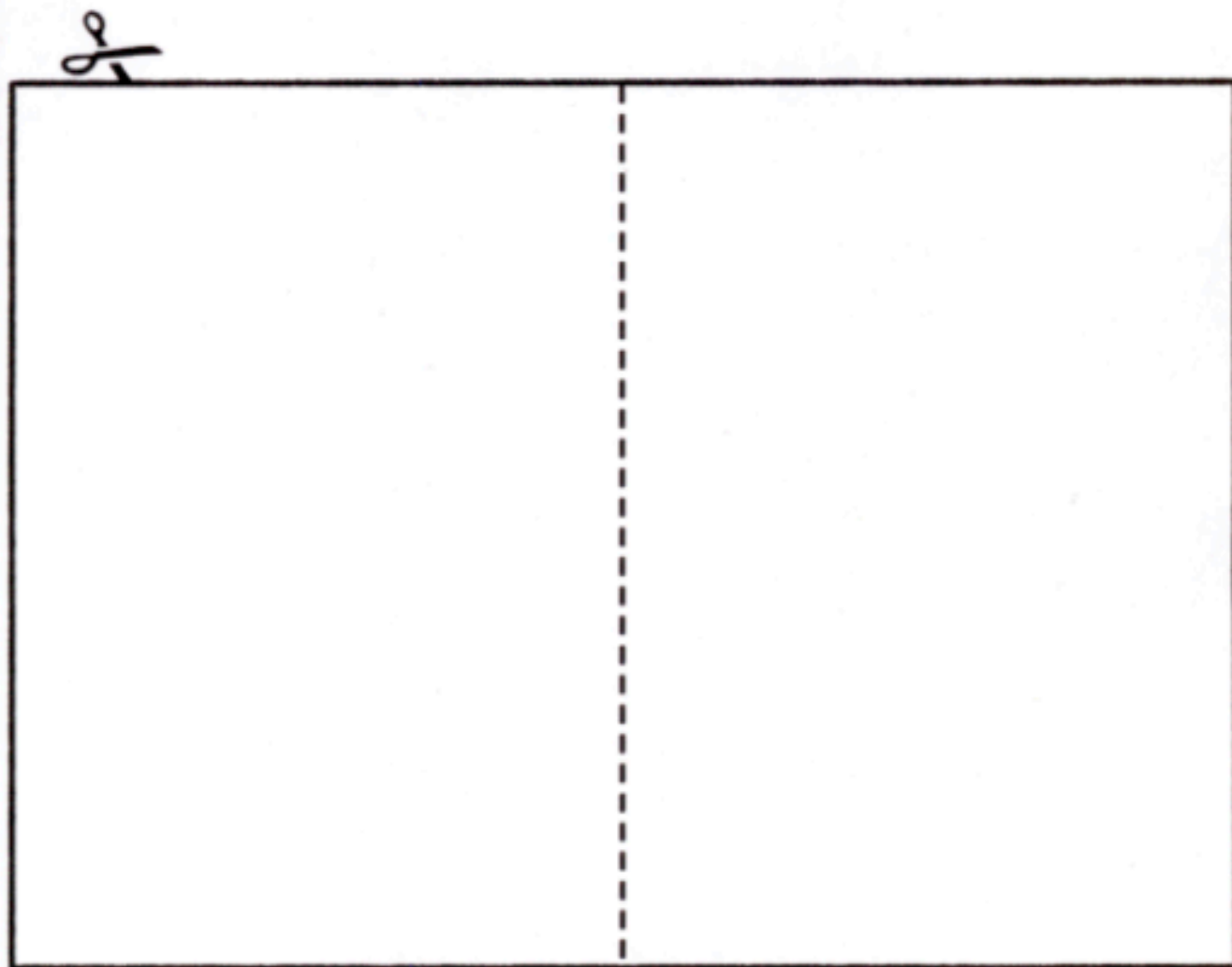

This page left blank intentionally so
card on page 23 can be cut out.

Build It Up, Knock It Down



Cut out the strips on the solid lines. Fold them along the dotted lines. Tape the ends together to form a triangle. Now use them to build something.



FOLD	FOLD
FOLD	FOLD
FOLD	FOLD
FOLD	FOLD
FOLD	FOLD
FOLD	FOLD

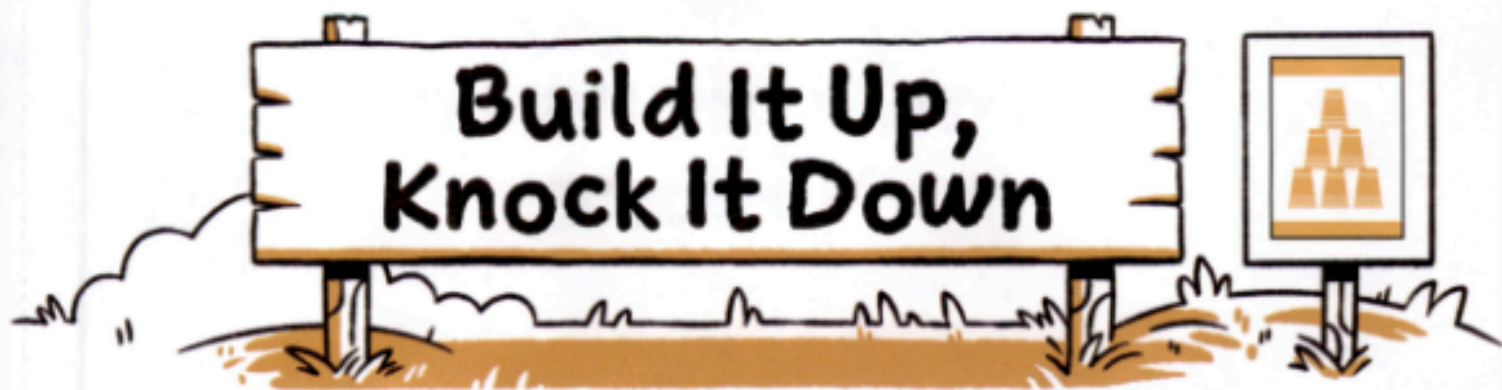

Draw a picture of your structure.

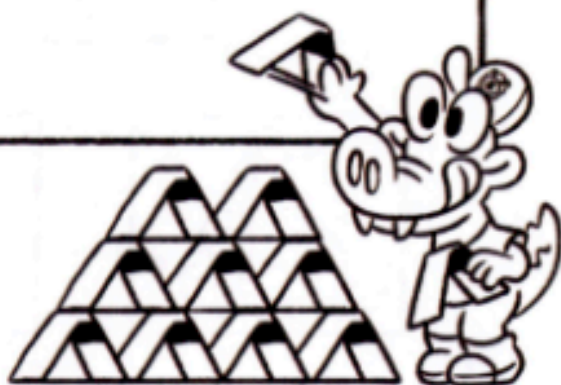
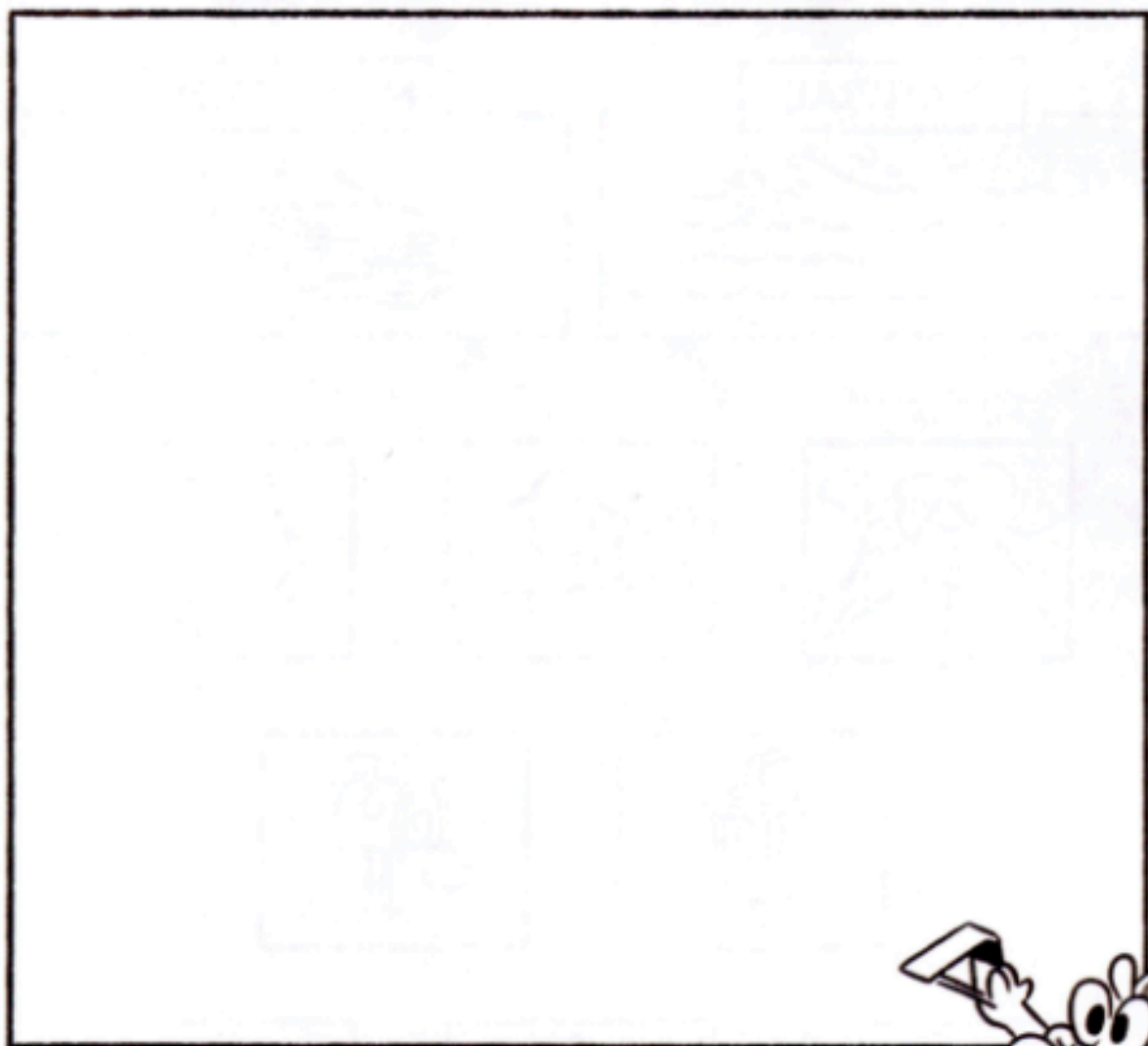

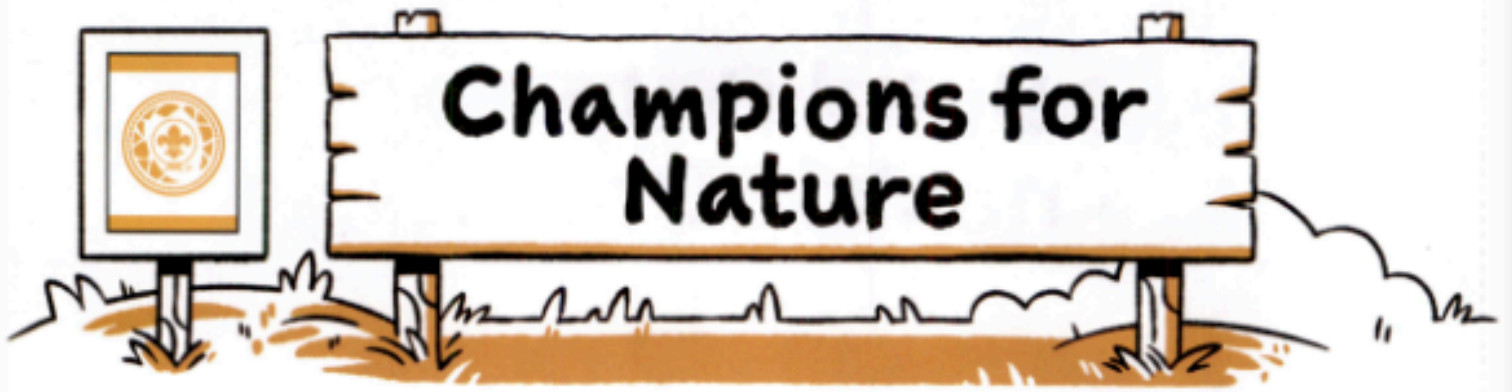

Draw a line to match each item to either
NATURAL or MAN-MADE.

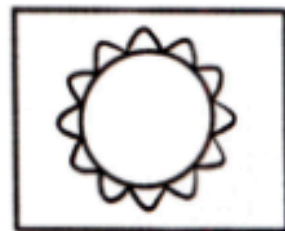
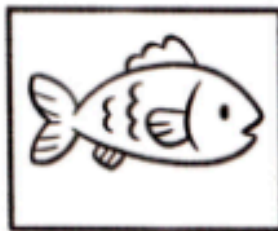
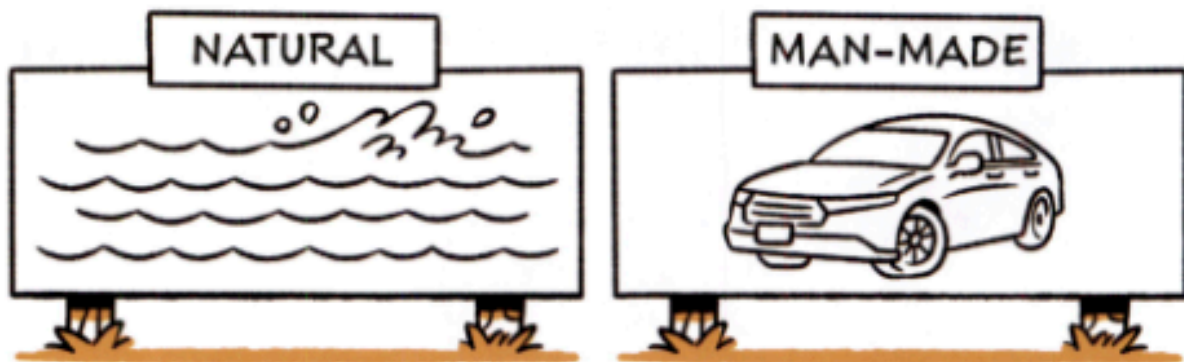



Color the waste.

Color all the organic waste GREEN.

Color all the paper waste YELLOW.

Color all the glass waste BLUE.



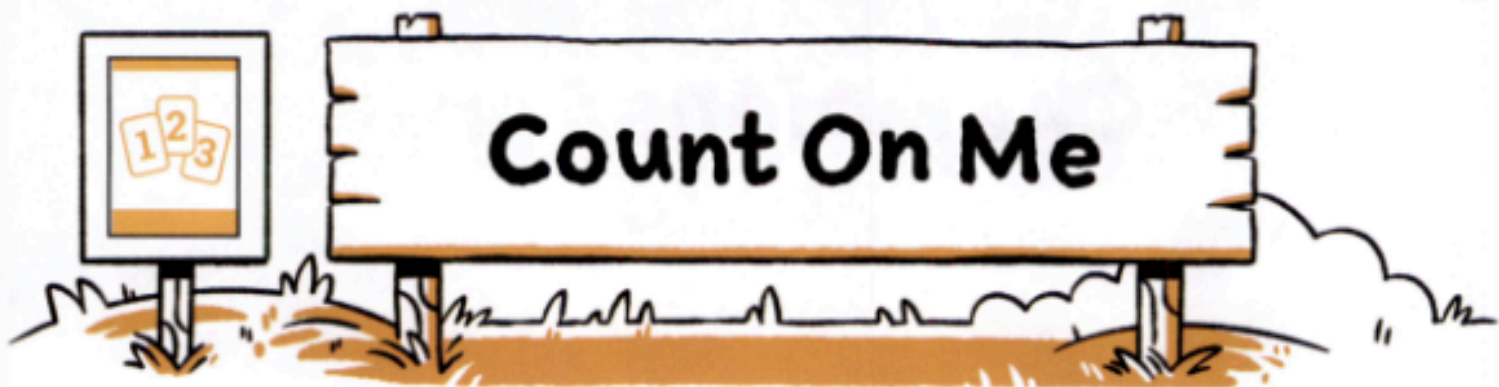

Count how many of each shape.
Write the number next to the shape below.

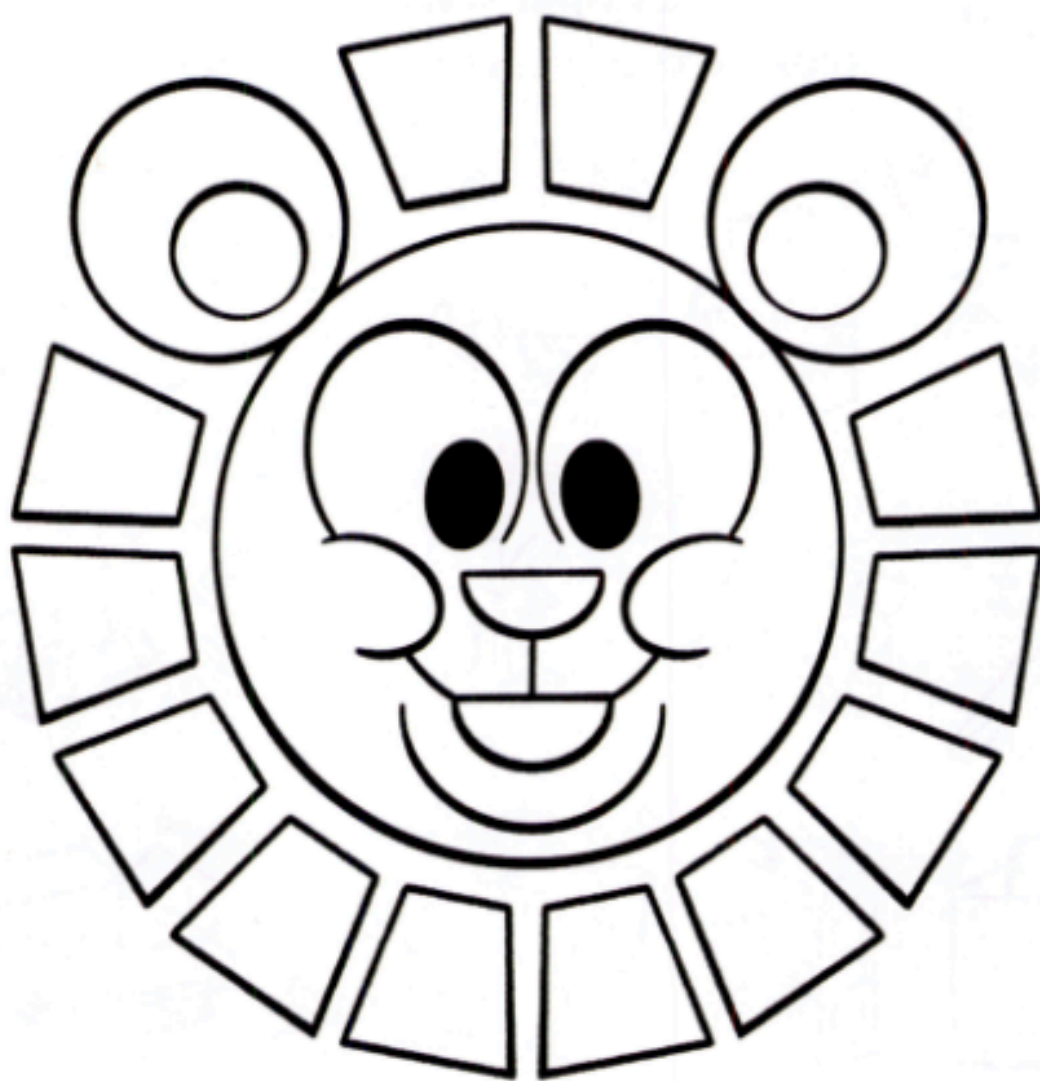

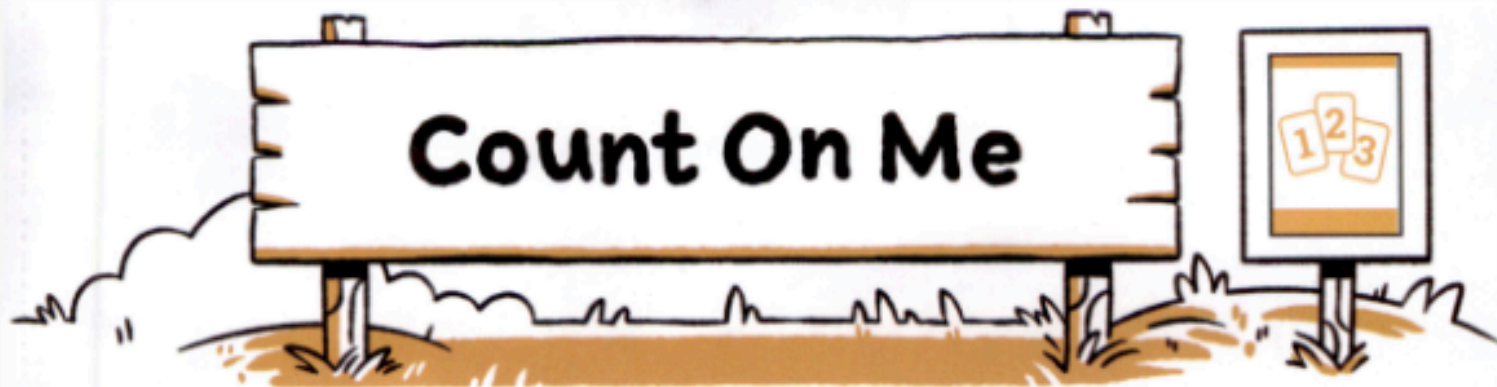

Cut out the shapes below. Glue or tape them together to make a lion like the one pictured here. Draw a face on your lion. Now it's done. ROAR!

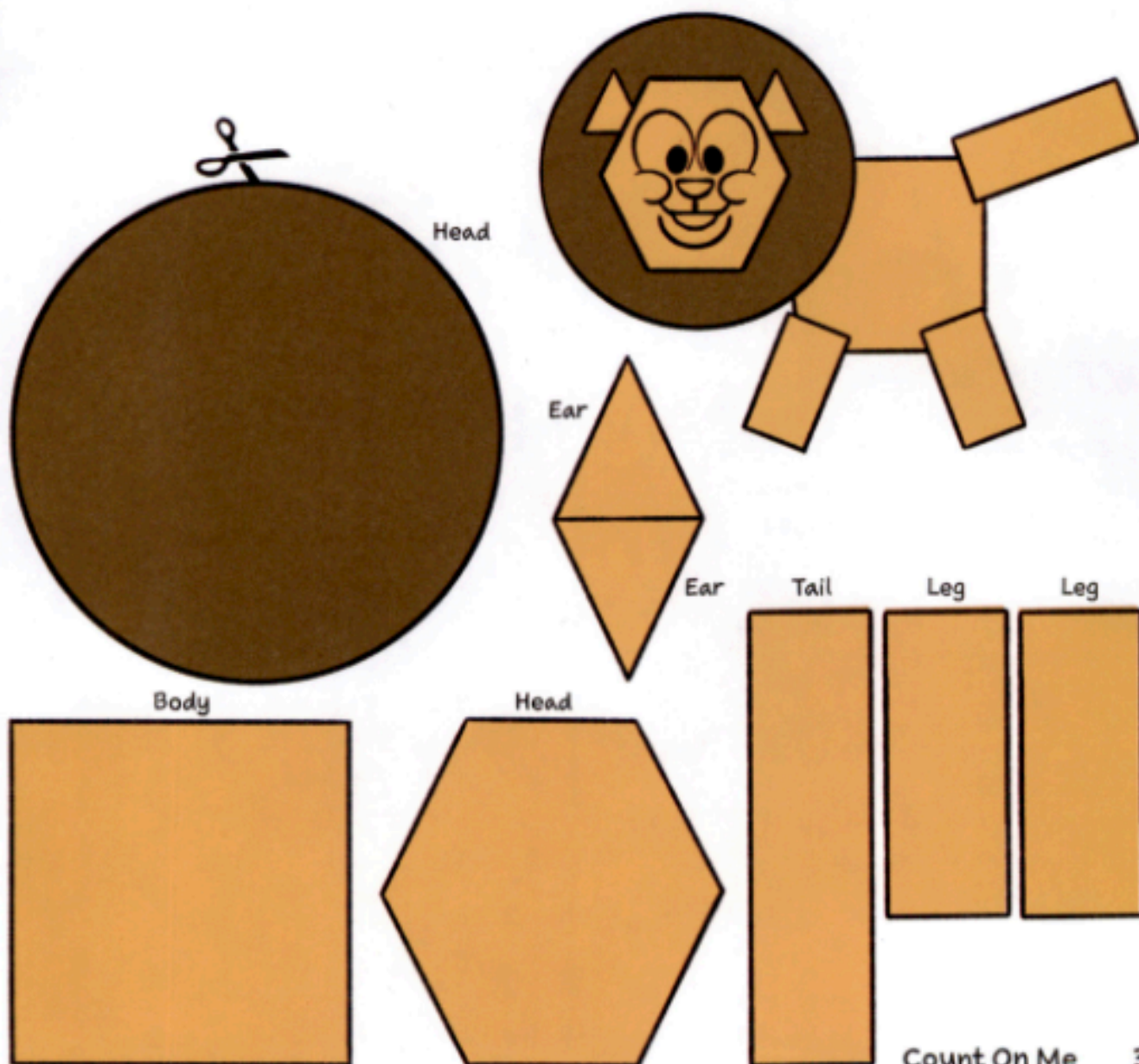

Everyday Tech



Circle the digital technology.

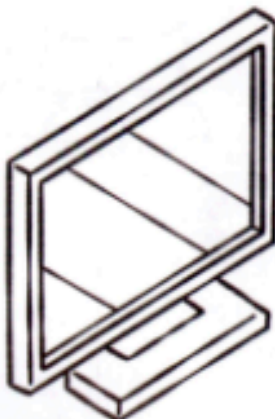
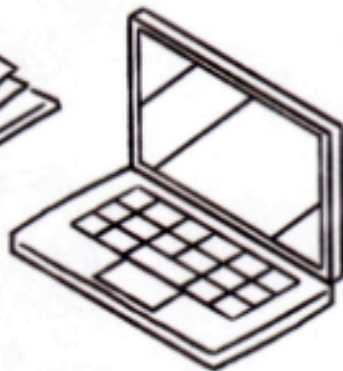
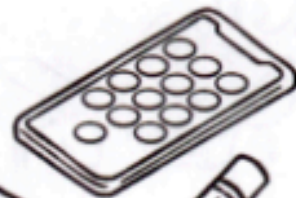
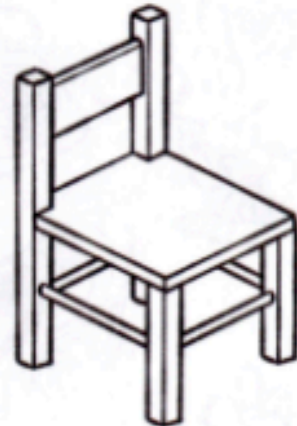
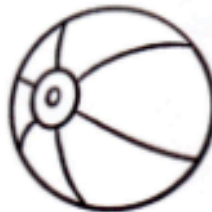



Everyday Tech

Draw a line to match the old and new technology.



Gizmos and Gadgets



Draw a picture of a gizmo that uses wheels.





Place an **X** on things that you **PUSH**.

Place an **O** on things you **PULL**.

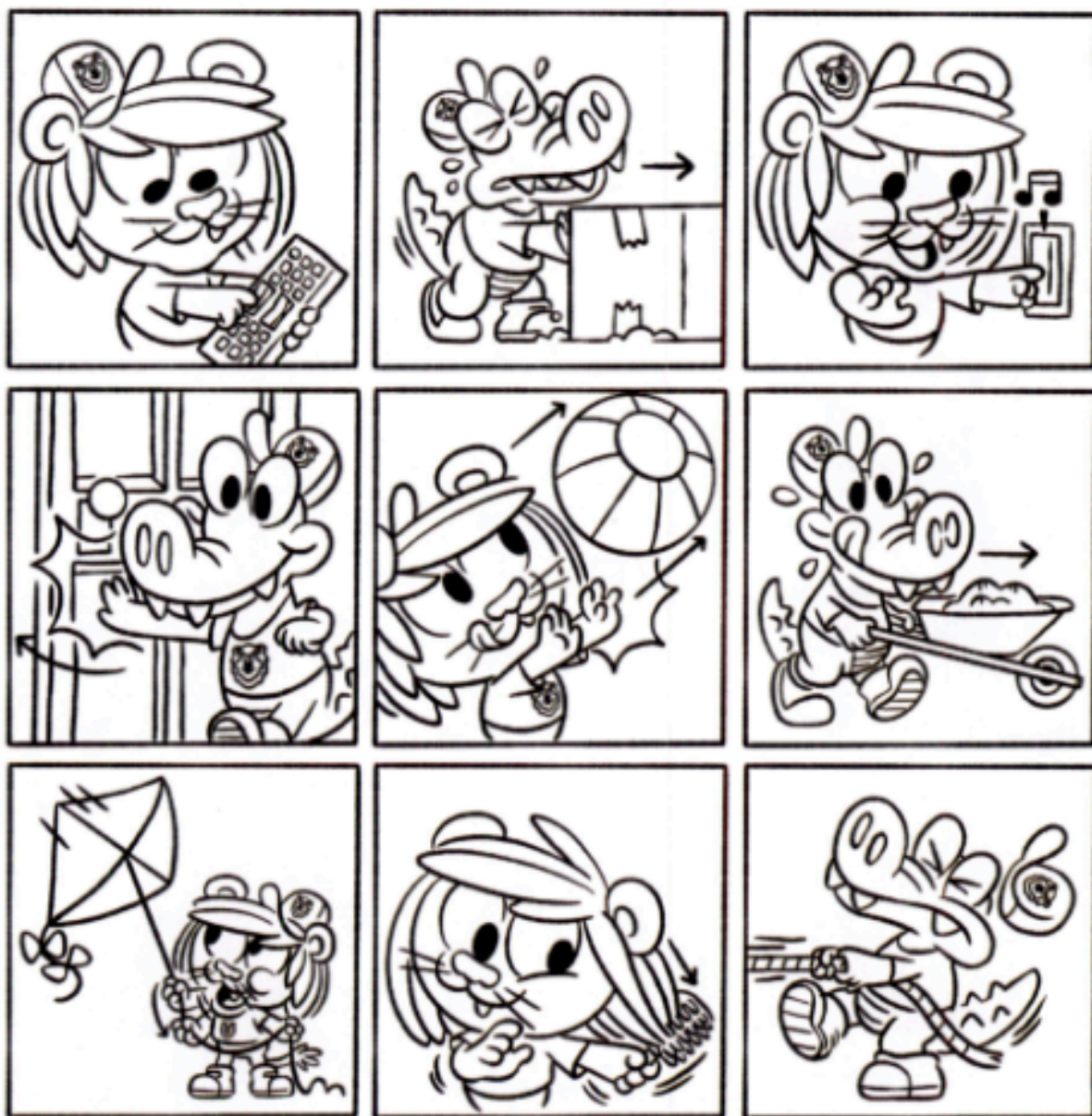

Gizmos and Gadgets



Follow the instructions below to build a bird feeder.

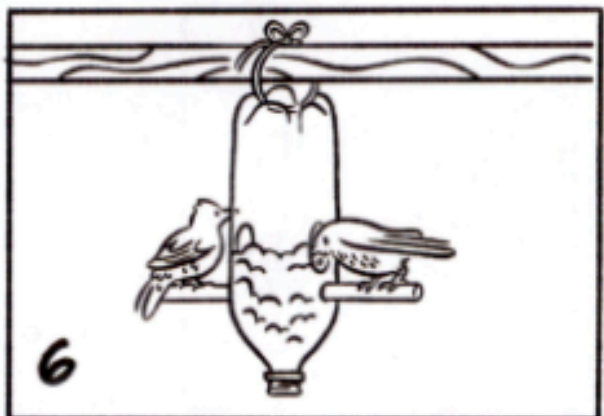
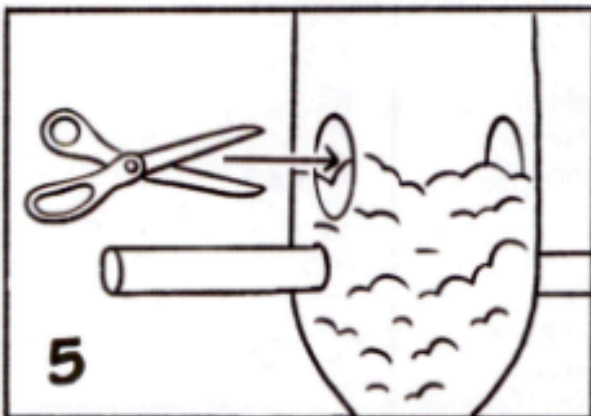
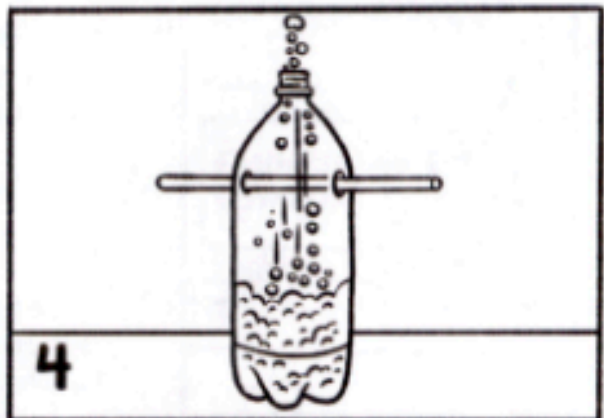
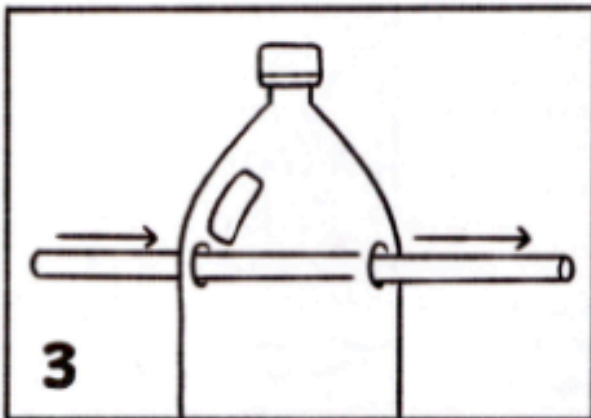
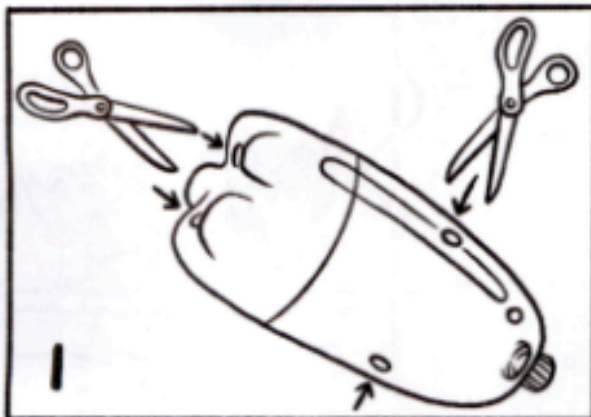



Match the picture to the rule.

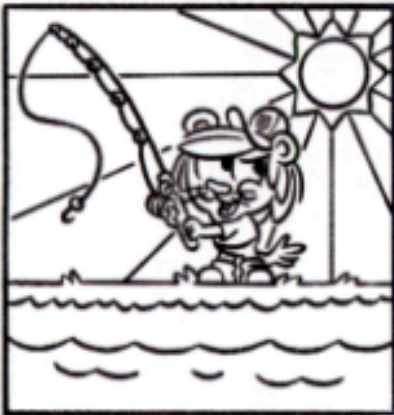

Fish with proper adult supervision.

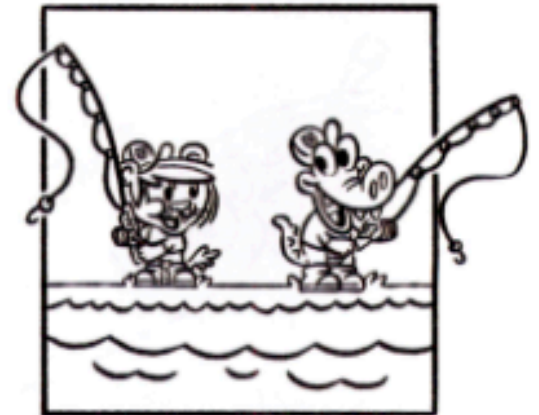

Get permission to fish where you plan to fish.

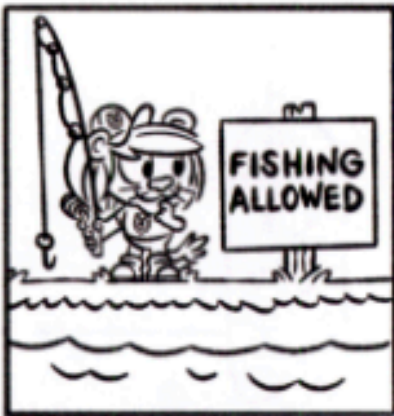

Check the weather before you go. Do not fish in a thunderstorm or bad weather.

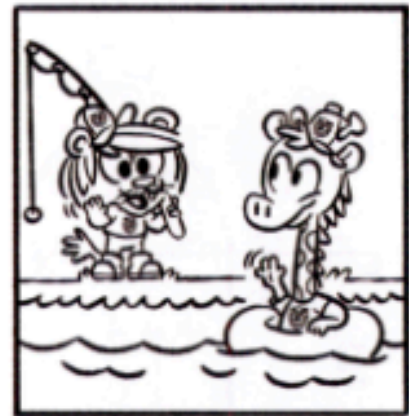

Use the buddy system. You must be able to see your buddy.



Give plenty of room to others who are fishing nearby.

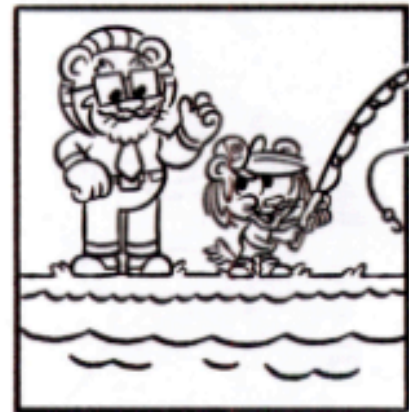

Never fish where people are swimming.

Go Fish



Color the fish. Cut out the pieces on the dotted lines. Mix up the pieces. Complete the puzzle.

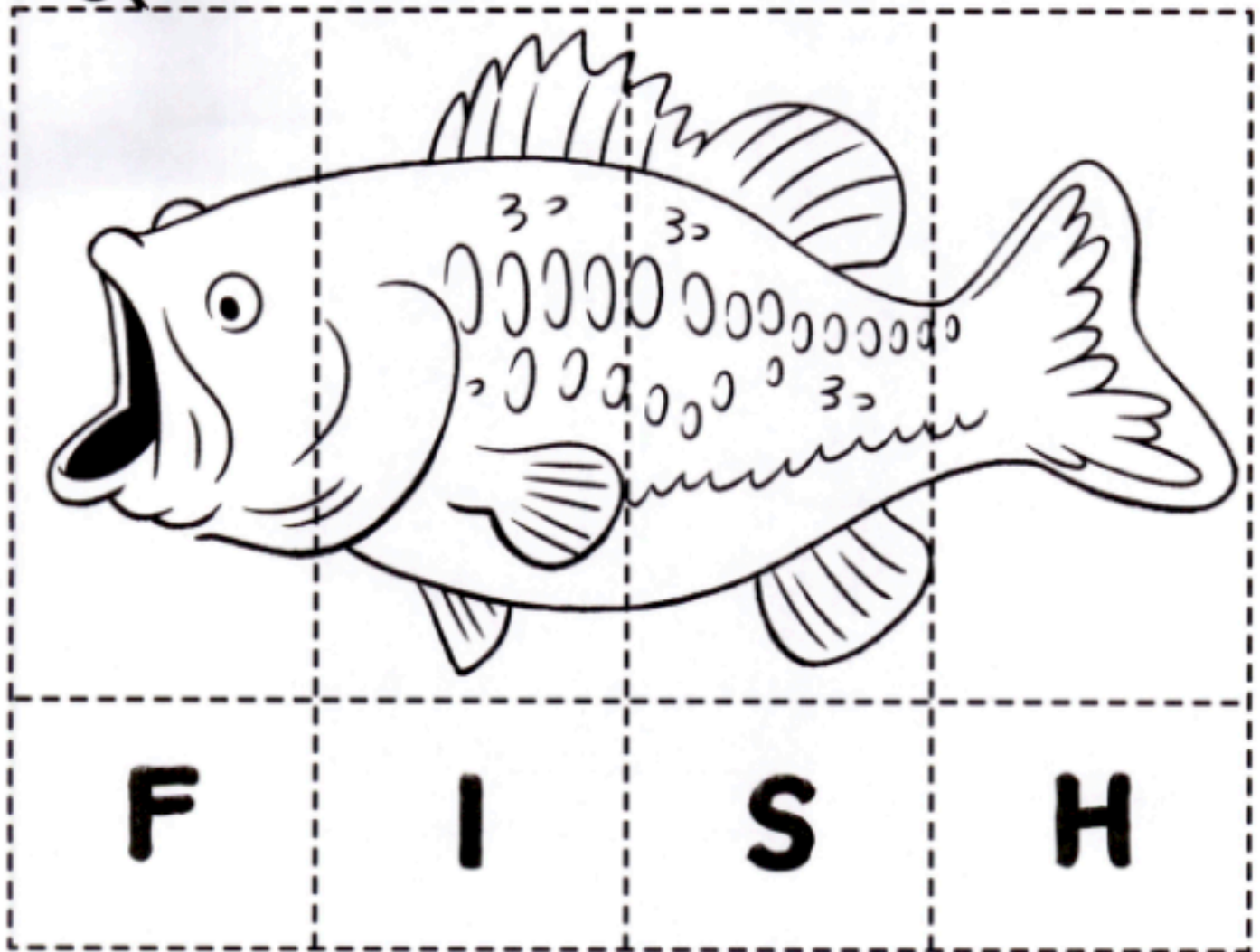
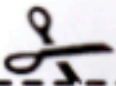

Go Fish



Copy the fish drawing using the grid lines as a guide. Copy one section at a time.

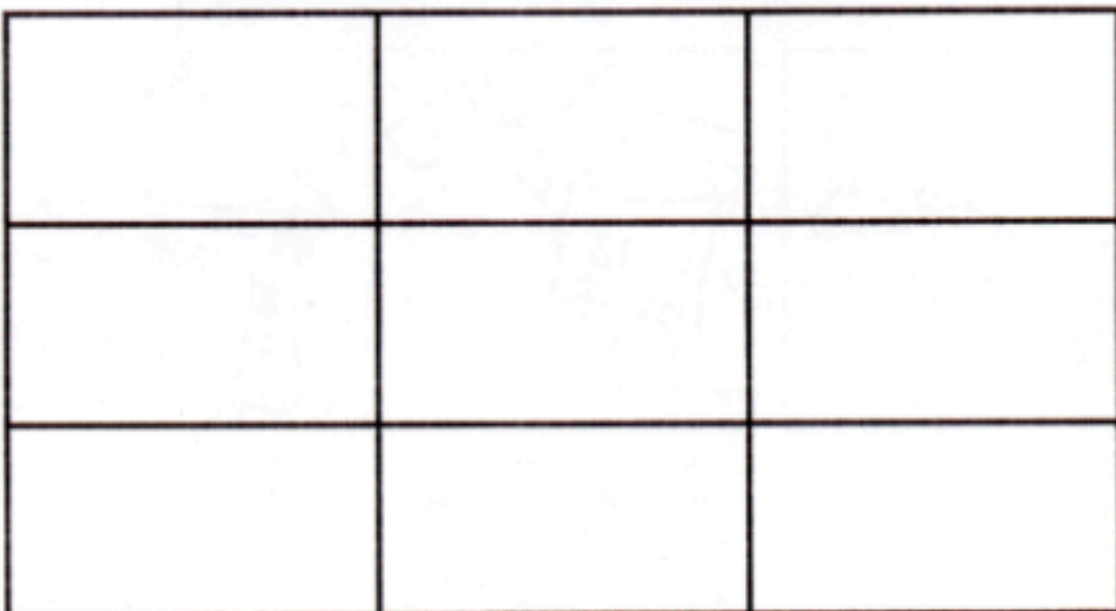
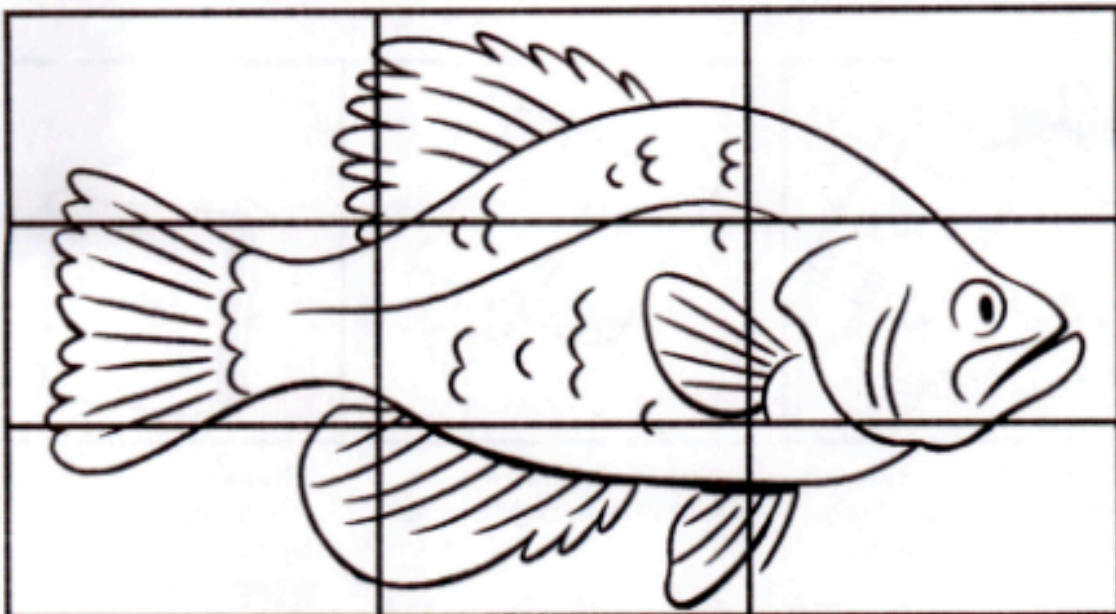



With the help of a trusted adult, follow the instructions to make your own Lion bag.



You will need a coat hanger, felt, scissors, a hot-glue gun, and hot glue sticks.



Cut the felt into a piece about 13 inches by 52 inches.



Drape the felt over the hanger. Glue the felt together below the hanger to keep it from sliding off.

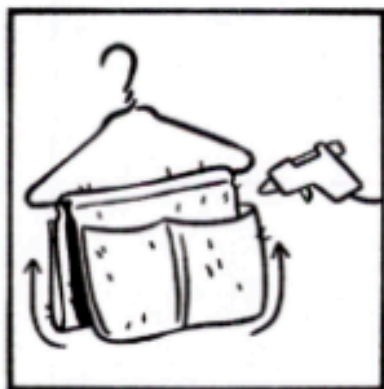

Fold the felt up on both sides. Glue the edges to form pockets. On one side, add a strip of glue in the middle to form two pockets.



Use the glue to write "Cub Scouts" or your name on the front.

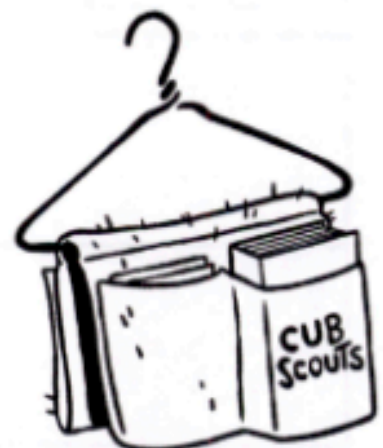

Add your handbook, neckerchief and slide, belt or other items in the pockets.

I'll Do It Myself



Tear out this page and post it in a place you will see it each morning.

Follow the steps to get ready for your day.



I went to the bathroom.



I brushed my teeth.

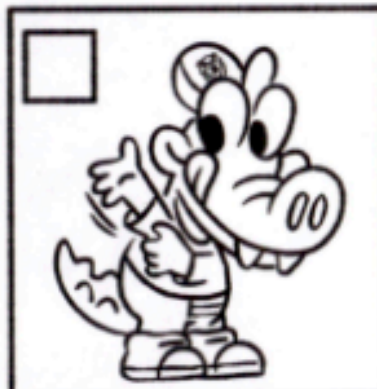

I got dressed.

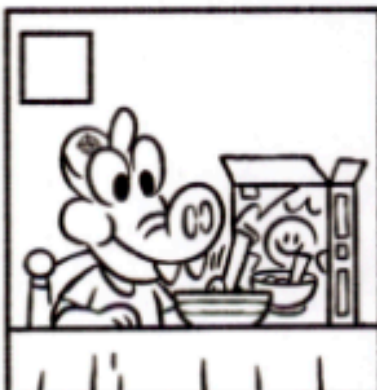

I ate breakfast.



I packed my backpack.



Let's go!

**This page left blank intentionally so
chart on page 43 can be torn out.**

I'll Do It Myself



Tear out this page and post it in a place you will see it each evening.

Follow the steps to get ready for bed.



I ate dinner.

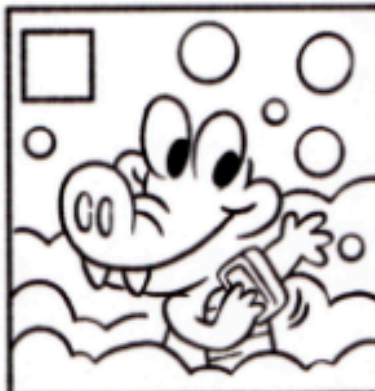

I bathed.



I put on my pajamas.

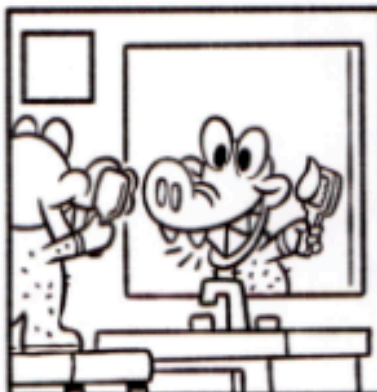

I brushed my teeth.



I went to the bathroom.



Good night.

This page left blank intentionally so
chart on page 45 can be torn out.

Let's Camp



Color the pictures that show buddies.

Put an X on each picture that does **NOT** show a buddy.

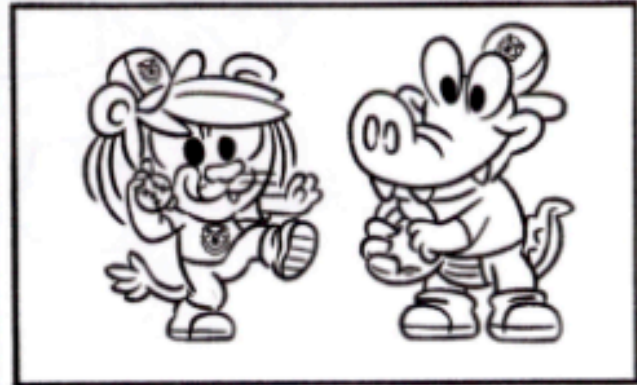
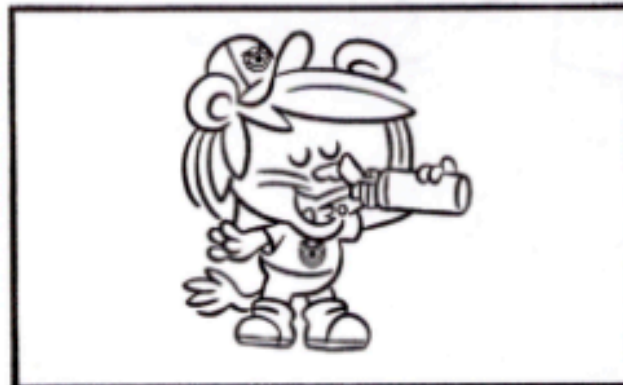
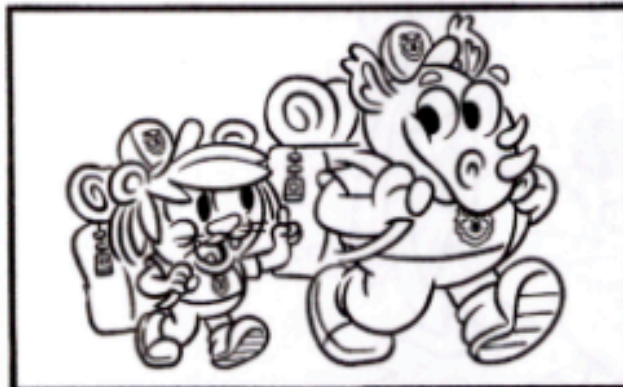
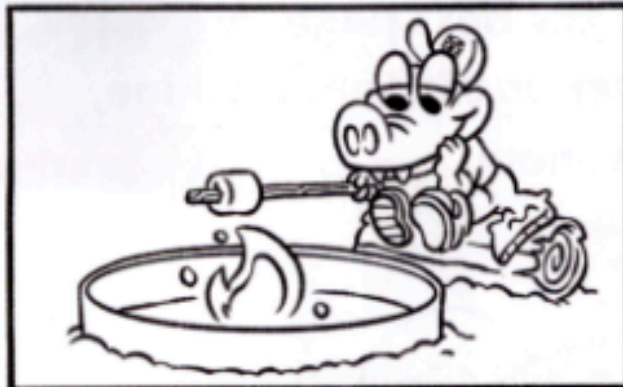



Dress Kat for each of the different types of weather.

With the help of a trusted adult, cut out the clothing items on the next page and dress Kat in the proper outfit for **sunshine, rain, and snow.**



Let's Camp



Raincoat and Boots



Umbrella



Hat



Shorts and Sneakers



T-shirt



Sunglasses



Winter Coat

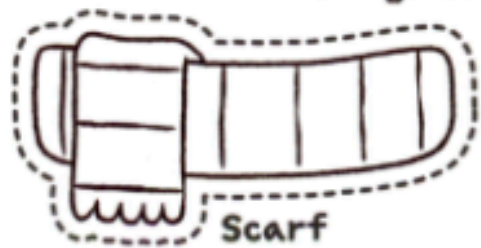

Scarf

Snowpants and Boots



Winter Hat



This page left blank intentionally so
clothes on page 49 can be cut out.

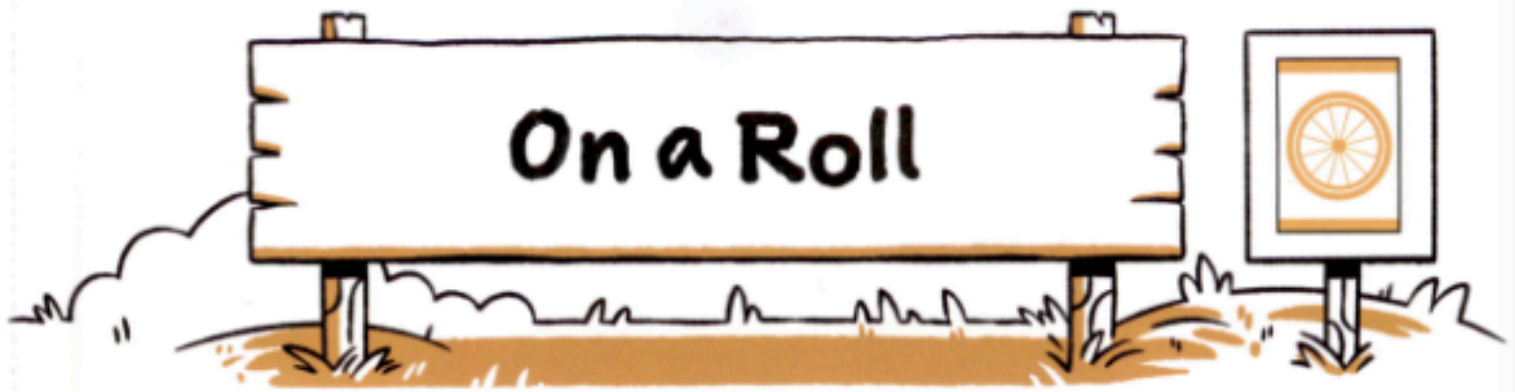

Complete the safety lesson.

Cut out the missing pictures
and complete the story.

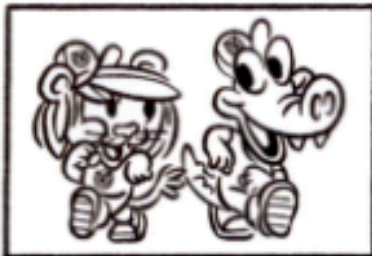

Ride with a buddy and
adult supervision.

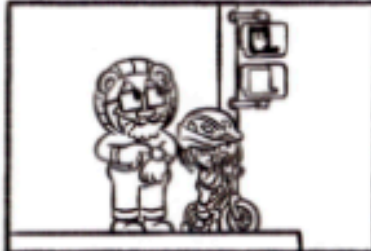

Walk your bike
across the street.



Wear a helmet
the right way.



Cut out and paste above.

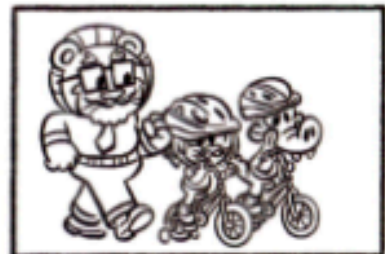
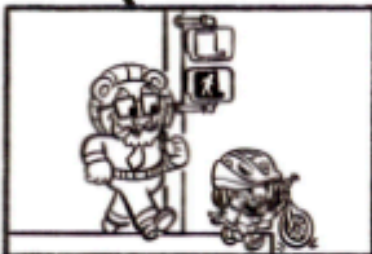

**This page left blank intentionally so
pictures on page 51 can be cut out.**

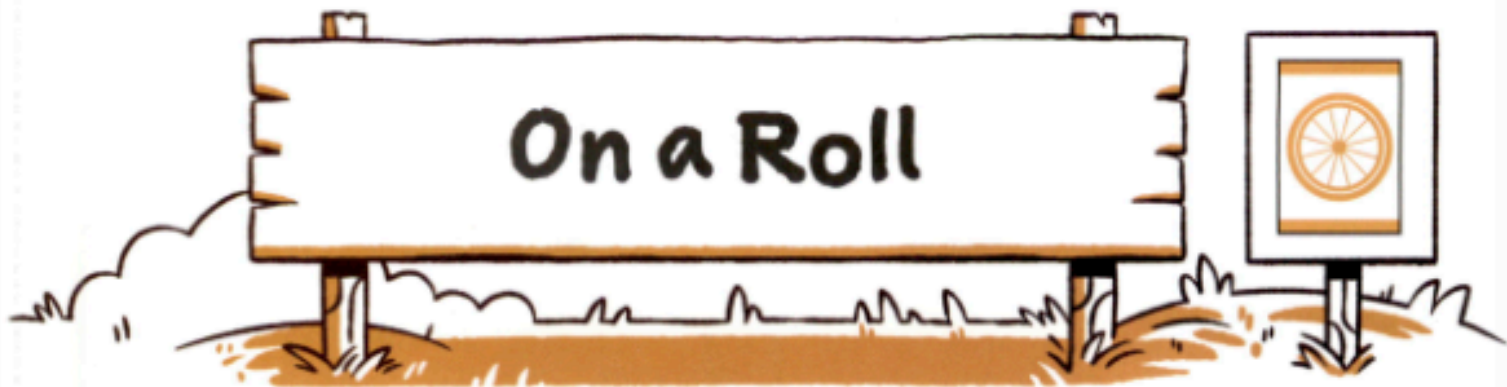

Complete the dot-to-dot and see your bicycle safety gear.

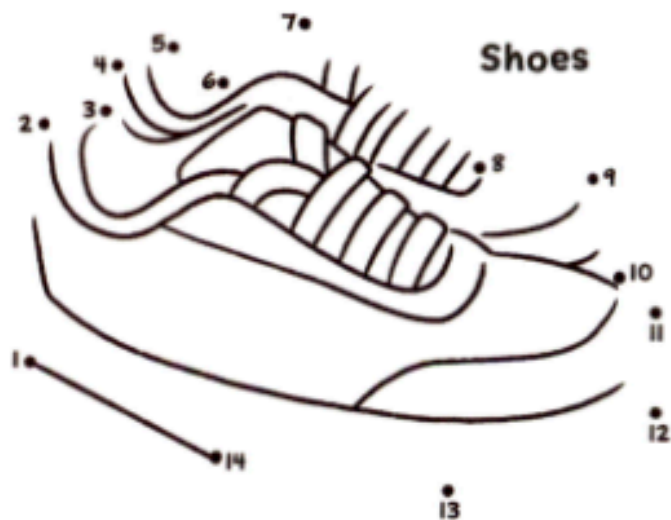
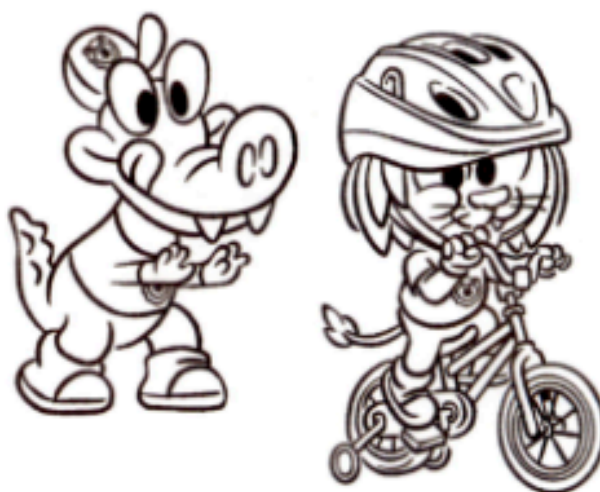
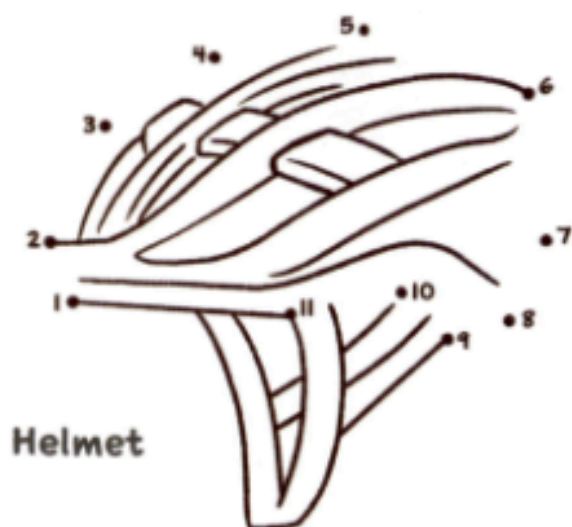



On Your Mark

Decorate this plain cardboard box
to look like a race car.

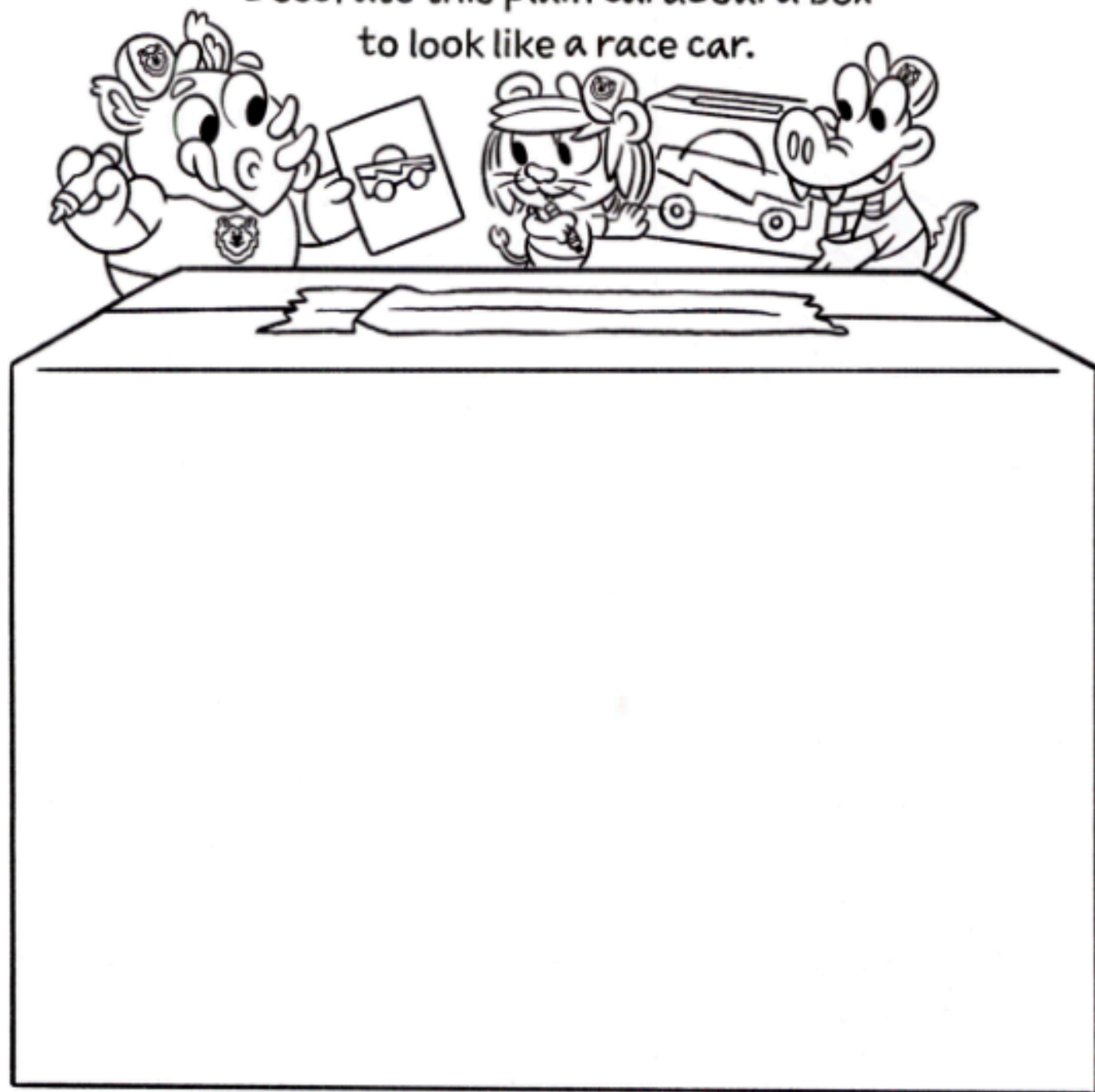

Race Time



Design your Pinewood Derby car on the template below. It's the exact size of the block of wood in your Pinewood Derby kit. Tear out this page and use it to trace your design onto the wood block. A trusted adult can help you cut the wood.

Top View



Side View



Front

Back



Color the paw prints.

Color four prints one color and the other four prints a different color. Cut out the prints and use them to play Pick My Path on page 59.

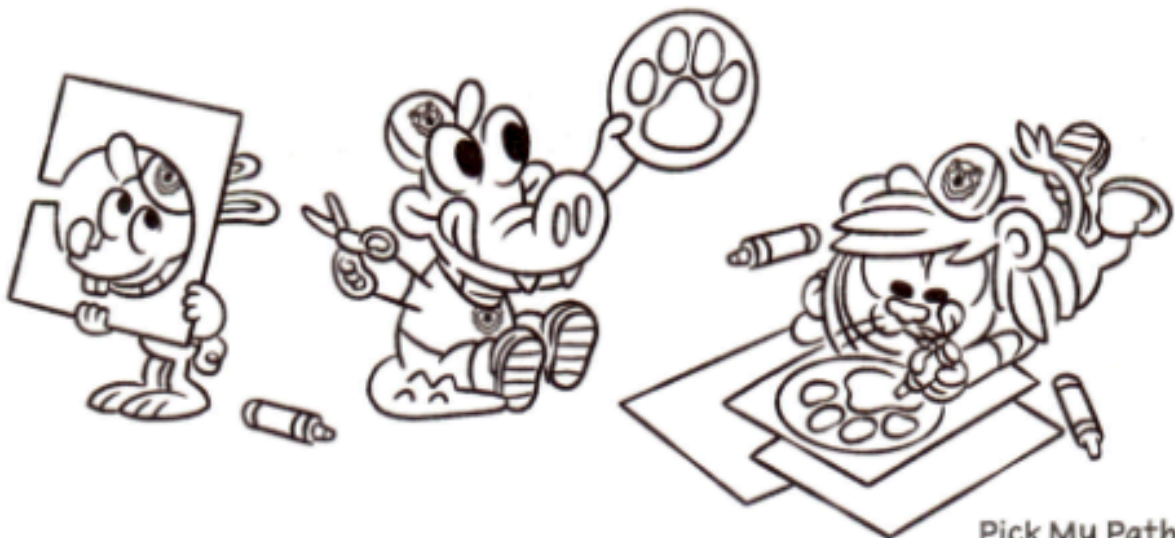

This page left blank intentionally so Pick My Path
paw prints on page 57 can be cut out.

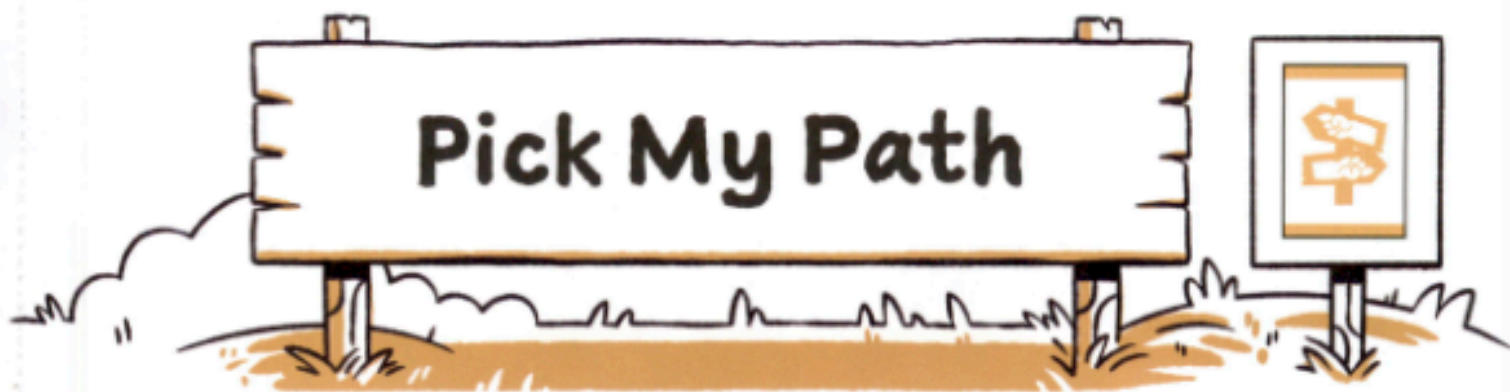

This grid can be used to play Pick My Path.
The game is like tic-tac-toe.

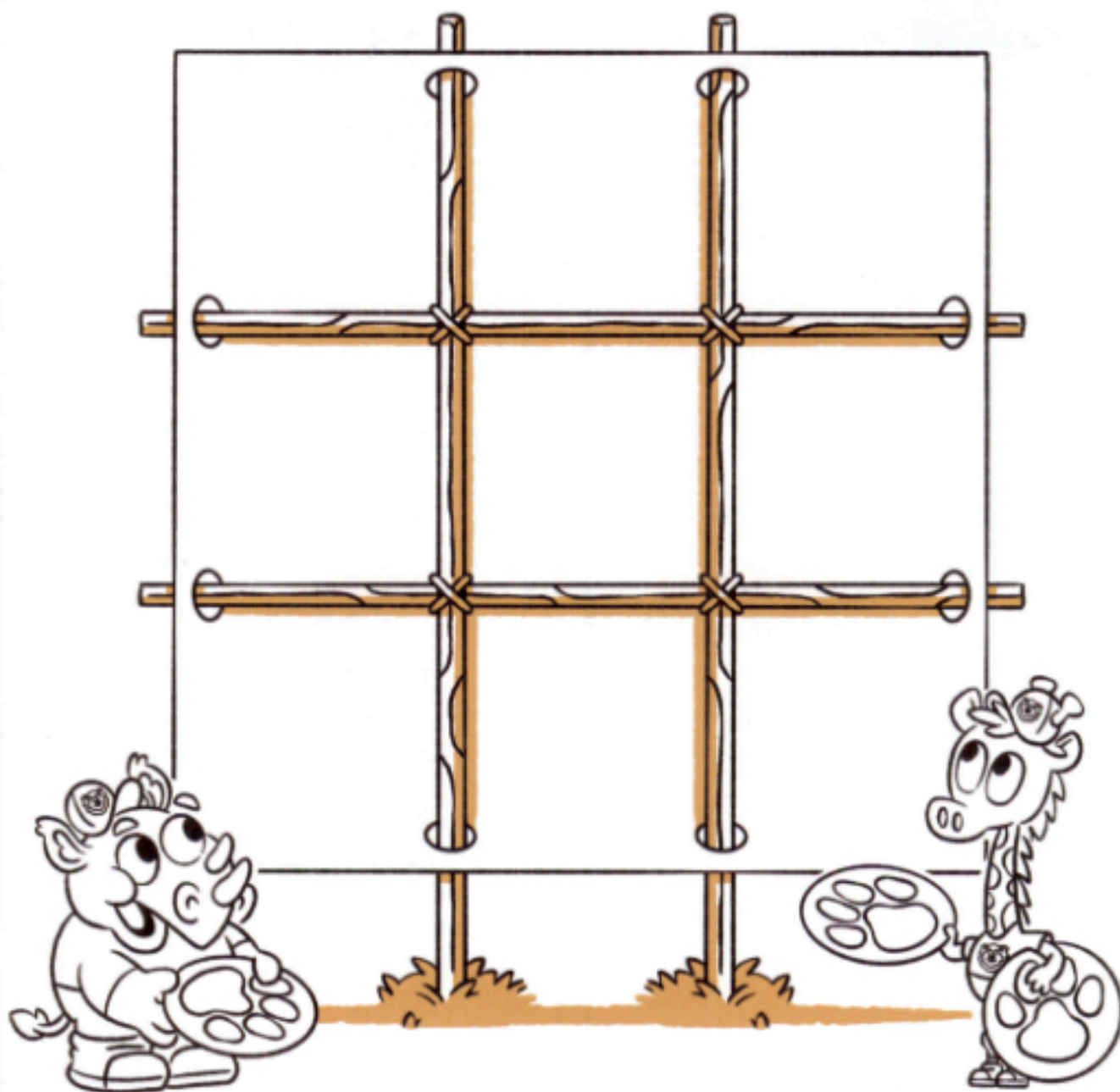

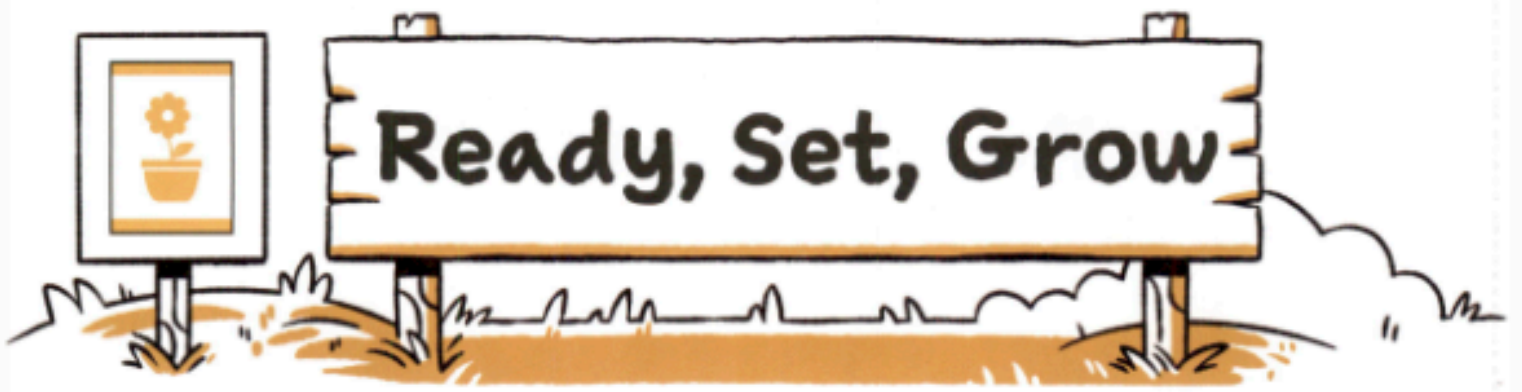

GROUND



TREE

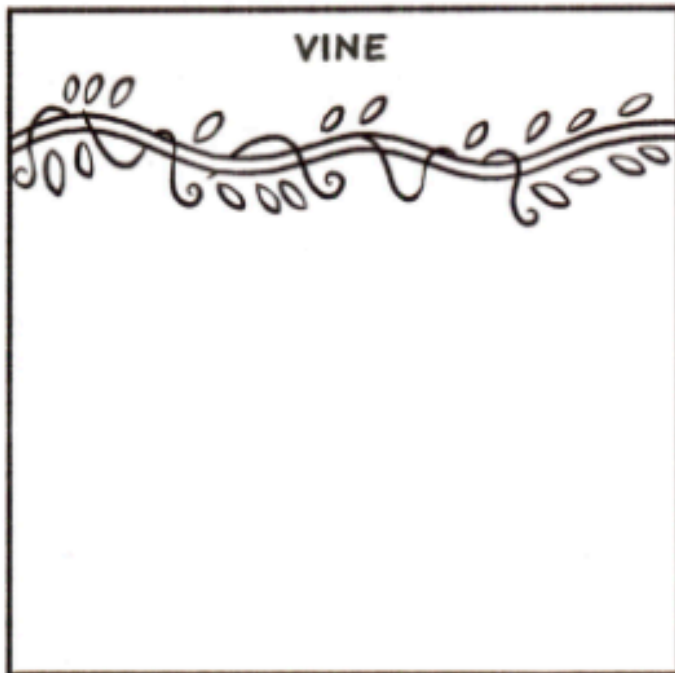

VINE

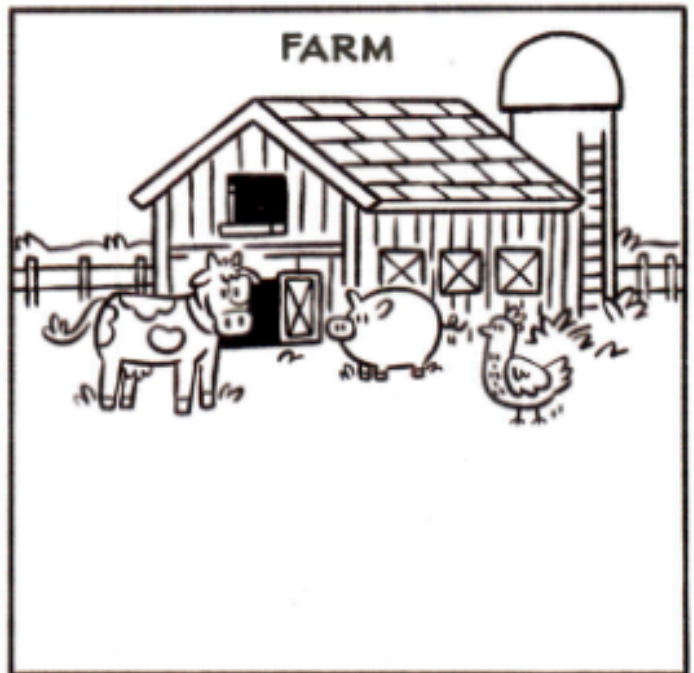

FARM

Ready, Set, Grow



Color the food below.
Cut out the food cards and match them to the
place they come from on page 60.

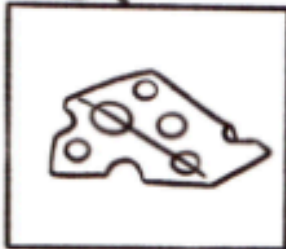

Cheese



Lettuce

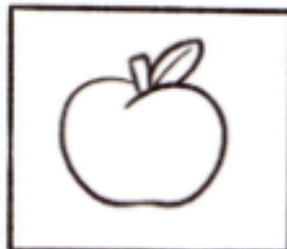

Apple



Milk



Orange



Pear

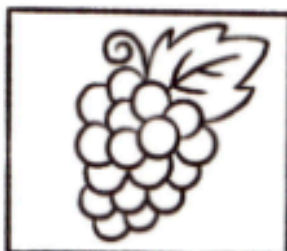

Grapes

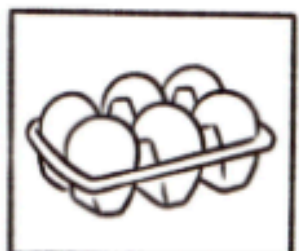

Eggs



Beans



Potato

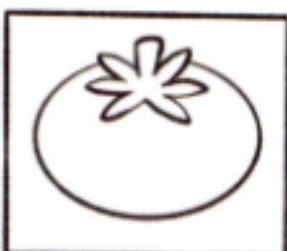

Tomato

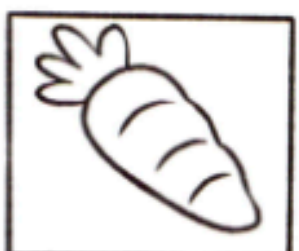

Carrot

**This page left blank intentionally so food cards
on page 61 can be cut out.**

Time to Swim



Color the picture below that shows everything needed for a safe swimming adventure.

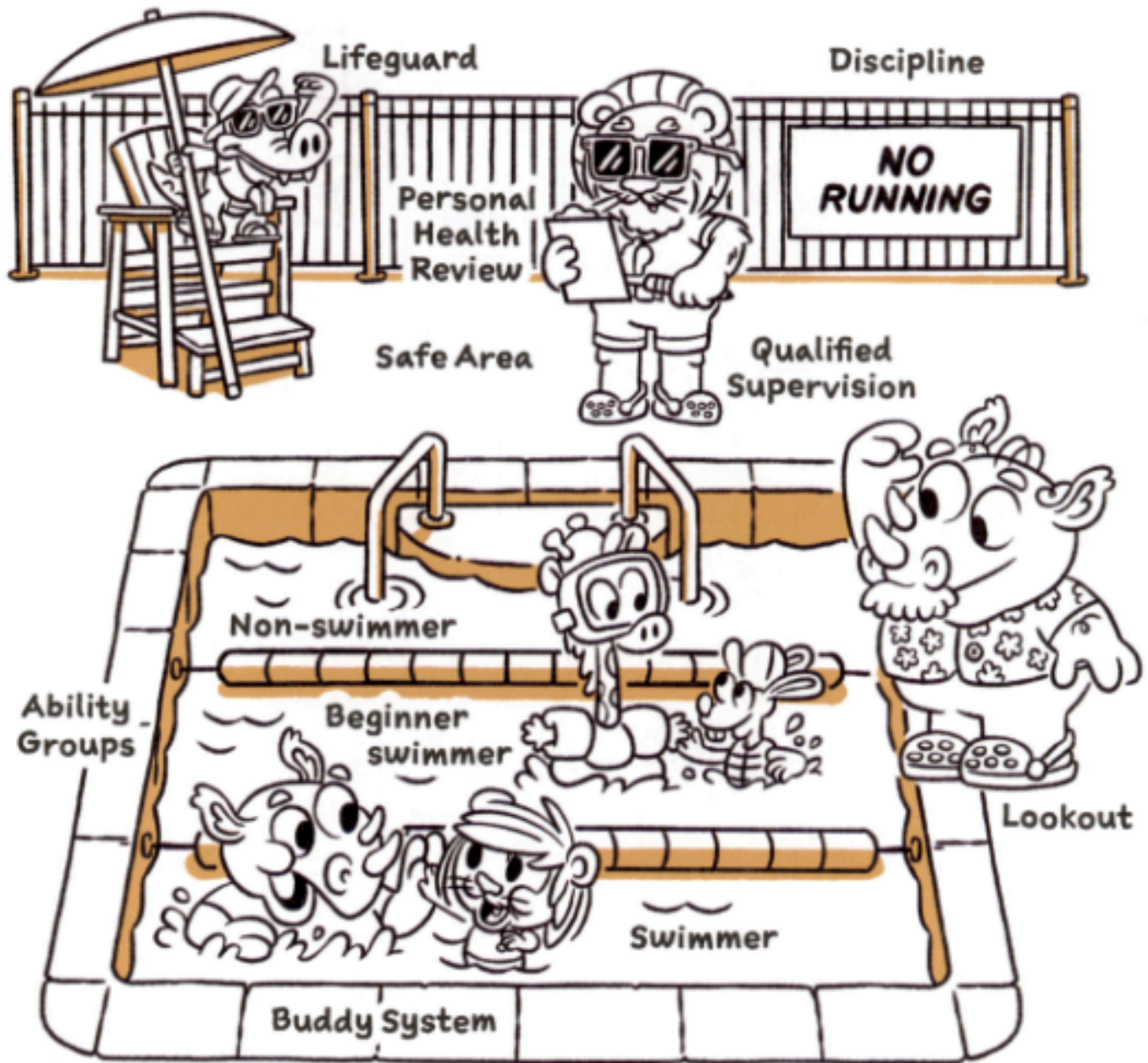



Put a check mark in the box above each Adventure once you complete it.

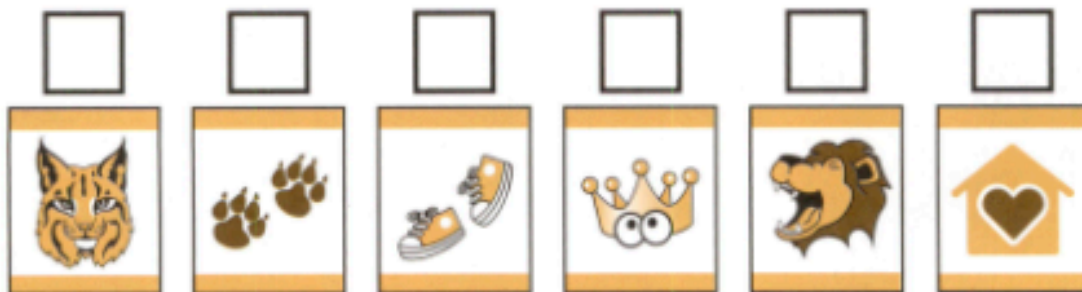

Bobcat Mountain Lion Fun on the Run King of the Jungle Lion's Roar Lion's Pride

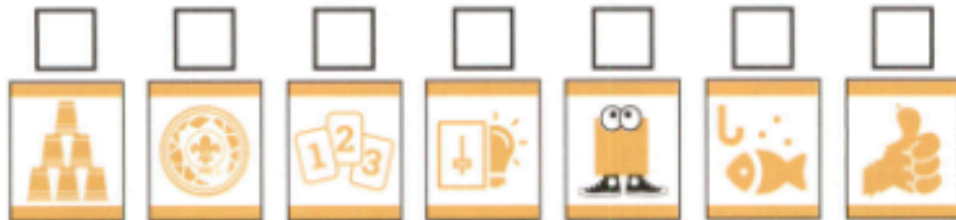

Build it Up, Knock it Down Champions for Nature Count On Me Everyday Tech Gizmos and Gadgets Go Fish I'll Do It Myself



Let's Camp On a Roll On Your Mark Pick My Path Race Time Ready, Set, Grow Time to Swim

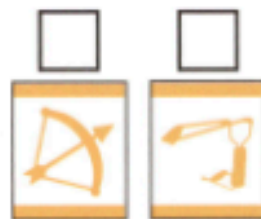

Archery* Slingshot*

* Range and target sports Adventures are special Adventures that can only be completed at approved events with qualified instructors.